



# SPIRIT

MEDICAL  
SYSTEMS GROUP

*A Heritage of Quality | The Spirit of Innovation*



## MT200 Rehabilitation Treadmill USER'S MANUAL



PLEASE READ THIS ENTIRE MANUAL CAREFULLY BEFORE OPERATING YOUR NEW TREADMILL AND SAVE IT FOR FUTURE USE.

# Table of Contents

Product Registration.....	2
Important Safety Instructions.....	3
Important Electrical Information.....	4
Important Operation Instructions.....	4
Application Specification.....	5
Operating Principle.....	5
Significant Physical Characteristics.....	6
Significant Performance Characteristic.....	6
Intended User Profile.....	6
Operating The MT200.....	7
Features.....	8
Operation of Your New Treadmill.....	11
MT200 Assembly Instructions.....	24
MT200 Drawing.....	30
MT200 Parts List.....	31
Maintenance.....	36
Maintenance Software Mode.....	38
Specifications.....	41
Description of Packaging Symbols.....	44
Manufacturer’s Limited Warranty.....	45



Thank you for your recent purchase of this high quality physical rehabilitation treadmill, the MT200, from Dyaco Canada Inc.

Your new product was manufactured by one of the leading fitness and medical products manufacturers in the world. Further, it is backed by one of the most comprehensive warranties in the industry. Through our dealers, distributors and manufacturer’s representatives, we will do all we can to provide many years of successful and prosperous ownership. Your warranty and service needs will be addressed collaboratively through your regional sales representative and our highly trained service technicians.

The responsibility of that collaborative team is to provide you with both the technical knowledge and access to service personnel to make your ownership experience more informed, and resolution of any difficulties easier to remedy.

Two components of Dyaco Canada Inc’s mission statement are “enhancing patient outcomes and improving effectiveness in the delivery of services”. This is just one of the many products that will assist you in providing that care to your patients and/or clients.

Please take a moment at this time to record the name of the dealer, distributor, or manufacturer’s representative, their telephone number, and the date of purchase below to make any future, needed contact easy. We appreciate your support and we will always remember that you are the reason that we are in business.

Please complete and mail your registration card today and enjoy your new MT200 treadmill.

Yours in Health and Wellness,  
Dyaco Canada Inc

## ***Product Registration***

### **RECORD YOUR SERIAL NUMBER**

Please record the Serial Number of this fitness product in the space provided below. You can find the serial number on a sticker that is located on the front of the treadmill.

**SN** \_\_\_\_\_

# Important Safety Instructions

- ⚠ **ATTENTION** - Read all instructions in this manual before using this device.
- ⚠ **DANGER** - To reduce the risk of electric shock disconnect your treadmill from the electrical outlet prior to cleaning and/or service work.
- ⚠ **WARNING**: Do not modify this equipment without authorization of the manufacturer.
- ⚠ **WARNING** - To reduce the risk of burns, fire, electric shock, or injury to persons, install the treadmill on a flat level surface with access to a 115 volt AC, 60 Hz, 20-amp grounded outlet. Do not use an extension cord unless it is 12awg (2.5mm<sup>2</sup>) or larger, with only one outlet on the end. The treadmill should be the only appliance in the electrical circuit. Do not attempt to disable the grounded plug by using improper adapters, or in any way modify the cord set; a serious shock or fire hazard may result along with computer malfunctions.
- ⚠ **WARNING**: To avoid risk of electric shock, this equipment must only be connected to a supply main with protective earth.
  - Use this device only for its intended use as described in this manual.
  - Keep children away from the treadmill. There are moving parts, obvious pinch points and other caution areas that can cause harm.
  - Except as instructed for use of the device, keep hands away from all moving parts.
  - Keep the electrical cord away from heated surfaces and out of all travel lanes and do not operate the treadmill if the cord or plug is damaged.
  - Never drop or insert any object into any openings.
  - Do not use outdoors.
  - To disconnect, turn all controls to the off position then remove the plug from the outlet.
  - This device is designed for commercial use and will meet the demands of orthopedic, sports wellness and general conditioning programs.
  - Do not attempt to use your treadmill for any purpose other than for the purpose it is intended.
  - The pulse sensors are not medical devices. Various factors, including the user's movement, may affect the accuracy of heart rate readings. The pulse sensors are intended only as exercise aids in determining heart rate trends in general.
  - **WARNING**: Heart rate monitoring system may be inaccurate. Over exercise may result in injury or death. If you feel faint stop exercising immediately.
  - Ensure there is a minimum space on the sides of the treadmill of two feet for proper operation, easy access and to prevent possible injuries to others standing or walking nearby. There should be a minimum of at least one foot of free space at the front and three and a half feet at the rear.
  - Do not use any after market parts on this device, other than those recommended by Spirit.
  - Do not attempt any servicing or adjustments other than those described in this manual. All else must be left to trained service personnel familiar with electro-mechanical equipment and authorized under the laws of the country in question to carry out maintenance and repair work.
  - Installation and assembly of this product should be performed by trained personnel only.
  - Hold the handlebar for support when getting on or off the treadmill.
  - To avoid injury please observe all minimum and maximum adjustment settings.
  - Wear proper shoes. High heels, dress shoes, sandals or bare feet are not suitable for use on the treadmill. Quality athletic shoes are recommended to avoid leg fatigue.
  - A safety tether cord is provided with this unit. It is a simple magnetic design that should be used at all times. It is for your safety should you fall or move too far back on the tread-belt. Pulling this safety tether cord will stop tread-belt movement.

# Important Electrical Information

## WARNING!

- ⚠ **NEVER** remove any cover without first disconnecting AC power. If voltage varies by ten percent (10%) or more, the performance of your treadmill may be affected. **Such conditions are not covered under your warranty.** If you suspect the voltage is low, contact your local power company or a licensed electrician for proper testing.
- ⚠ **NEVER** expose this product to rain or moisture. This product is **NOT** designed for use outdoors, near a pool or spa, or in any other high humidity environment.
- ⚠ The MT200 is **NOT** protected against the ingress of water or particulate matter.
- ⚠ The MT200 is not suitable for use in an oxygen rich environment.
- ⚠ If not stated otherwise Spirit devices are designed for operation in normal climatic surroundings (IEC 60601-1):
  - Temperature: + 10° ... + 36° C
  - Relative humidity: 30 ... 90 % (non condensing)
  - Air pressure: 700 ... 1060 mbar
  - Maximum operating altitude: approx. 10,000 feet (3000m), without pressurization
  - Transport and store the devices at a temperature of – 20° ... + 50° C.

## Grounding Instructions

**This product must be grounded.** In the unlikely event that the treadmill's electrical system should malfunction or breakdown grounding provides a path of least resistance for electric current, reducing the risk of electric shock. This product is equipped with a cord having an equipment-grounding plug. The plug must be plugged into an appropriate outlet that is properly installed and grounded in accordance with all local codes and ordinances.

- ⚠ **DANGER - Improper connection of the equipment-grounding conductor can result in a risk of electric shock. Check with a qualified electrician or serviceman if you are in doubt as to whether the product is properly grounded. Do not modify the plug provided with the product if it will not fit the outlet; have a proper outlet installed by a qualified electrician.**

## Important Operation Instructions

- **NEVER** use the treadmill during an electrical storm. Surges may occur in your facility power supply that could damage the treadmill's components.
- **All users** should have medical clearance before starting any rigorous exercise program.
- **Start the user** at a safe exercise level. Do not allow the user to be over exerted. Symptoms to watch for, but not limited to, are: Shortness of breath or difficulty in breathing, pain or discomfort, feeling faint.
- **Make sure** the user warms up and cools down properly to avoid over taxing the cardio vascular system. Allow three to five minutes of warm up and cool down during each exercise session.

# Application Specification

## Medical Purpose:

1. Patient warm up before physical therapy session.
2. Have the patient walk to improve ambulation and range of motion after knee/hip/ankle surgery or neurological conditions.
3. Allow patients to perform cardiovascular exercise.

## Intended Patient Population:

- There is no particular restriction on age, gender, height and nationality.
- Maximal patient's weight is 200kg.
- Patient must be ambulatory.
- Patient should have medical clearance before starting any rigorous exercise program. This is especially important for person with a history of heart disease or other high risk factors.

## Intended Part of the Body or Type of Tissue Applied to or Interacted with:

1. Contact site: Hands and feet
2. Condition: Should not have any trauma

## Intended Conditions of Use:

1. Environment including hygienic requirements:
  - (a) General: Intended for indoors use. This product is **NOT** designed for use outdoors, near a pool or spa, or in any other high humidity environment.
  - (b) Conditions of visibility:
    - Ambient luminance: Standard ambient room lighting is sufficient.
    - Viewing distance: 1 m
    - Viewing angle: 120°
  - (c) Physical:
    - Temperature range: 10°C ~ 36°C
    - Relative humidity range: 30% R.H. ~ 90% R.H., non condensing
  - (d) Hygienic requirements: There is no particular restriction on hygienic requirements.
2. Frequency of use: Dependant on therapist's plan.
3. Location: Intended for hospital use, clinic use, home use and research in academic institutions.
4. Mobility: The product is intended to be fixed.

# Operating Principle

The operator will start the device and use the speed and incline keys to control motors. When the speed key is pressed a signal is sent to the AC motor invert to request a change. The invert will then send the appropriate amount of power the AC drive motor to reach the requested speed. The motor drives the front roller (which in turn moves the walking Belt) through pullers and fan Belt. The incline motor is operated when the operator presses the incline keys. A command is generated that is transmitted to the incline control board where a relay is energized sending AC power to the motor until it reaches the desired position.

# ***Significant Physical Characteristics***

Please refer to **Features** of MT200 manual.

# ***Significant Performance Characteristic***

Please refer to “Unique uses for the Spirit Treadmill” in **Operating The MT200** of MT200 manual.

# ***Intended User Profile***

Intended user:

1. Intended operator
  - There is no particular restriction on age, gender, height, weight, ability and culture.
  - Education: University or above
  - Knowledge: The operator should read the User’s Manual before use.
  - Discipline: The operator should receive training from the manufacturer before use.
  - Experience: The operator must have experience in physical therapy.
  - Background: The operator must be a major in physical therapy.
  - Professional competence: The operator should have the physical therapist license.
  
2. Intended Installer
  - There is no particular restriction on age, gender, height, weight, ability and culture.
  - Education: High School or above
  - Knowledge: The installer shall be able to manipulate this product properly.
  - Discipline: The installer shall be given a specific training by manufacturer.
  - Experience: The installer must have experience in product assembly and disassembly.
  - Background: The installer must be electro-mechanically trained.
  - Professional competence: Normal vision ability required.

# Operating The MT200

The Spirit Medical Systems Group physical rehabilitation treadmill is intended to be used in aiding in the physical rehabilitation process for patients with orthopedic and neurological problems. Also used in sports medicine, wellness and general conditioning programs.

Typical applications for this type of product are:

1. Patient warm up before physical therapy session.
2. Have the patient walk to improve ambulation and range of motion after knee/hip/ankle surgery or neurological conditions.
3. Allow patients to perform cardiovascular exercise.

Unique uses for the Spirit Treadmill:

1. The walking belt allows for both forward and reverse walking.
2. The front and rear incline allows for uphill and downhill walking.
3. Symmetry program measures distance between left and right step lengths. Graphical Bio-feedback display motivates patients to maintain even step symmetry between left and right legs.

Other features of the MT200:

- Belt speed settings start at 0.1 km/hr.
- The parallel handrails are adjustable to accommodate for pediatric to large adult sizes.
- Heart Rate monitoring using the optional heart rate chest-strap.

\*Heart rate measurements are not for medical use:

*“The heart rate function on this product is not a medical device and should not be relied on when accurate readings are necessary. Some people, including those in a cardiac rehab program, may benefit from using an alternate heart rate monitoring system like a chest or wrist strap. Various factors, including movement of the user, may affect the accuracy of your heart rate reading. The heart rate reading is intended only as an exercise aid for measuring heart rate trends in general.*”



# Features

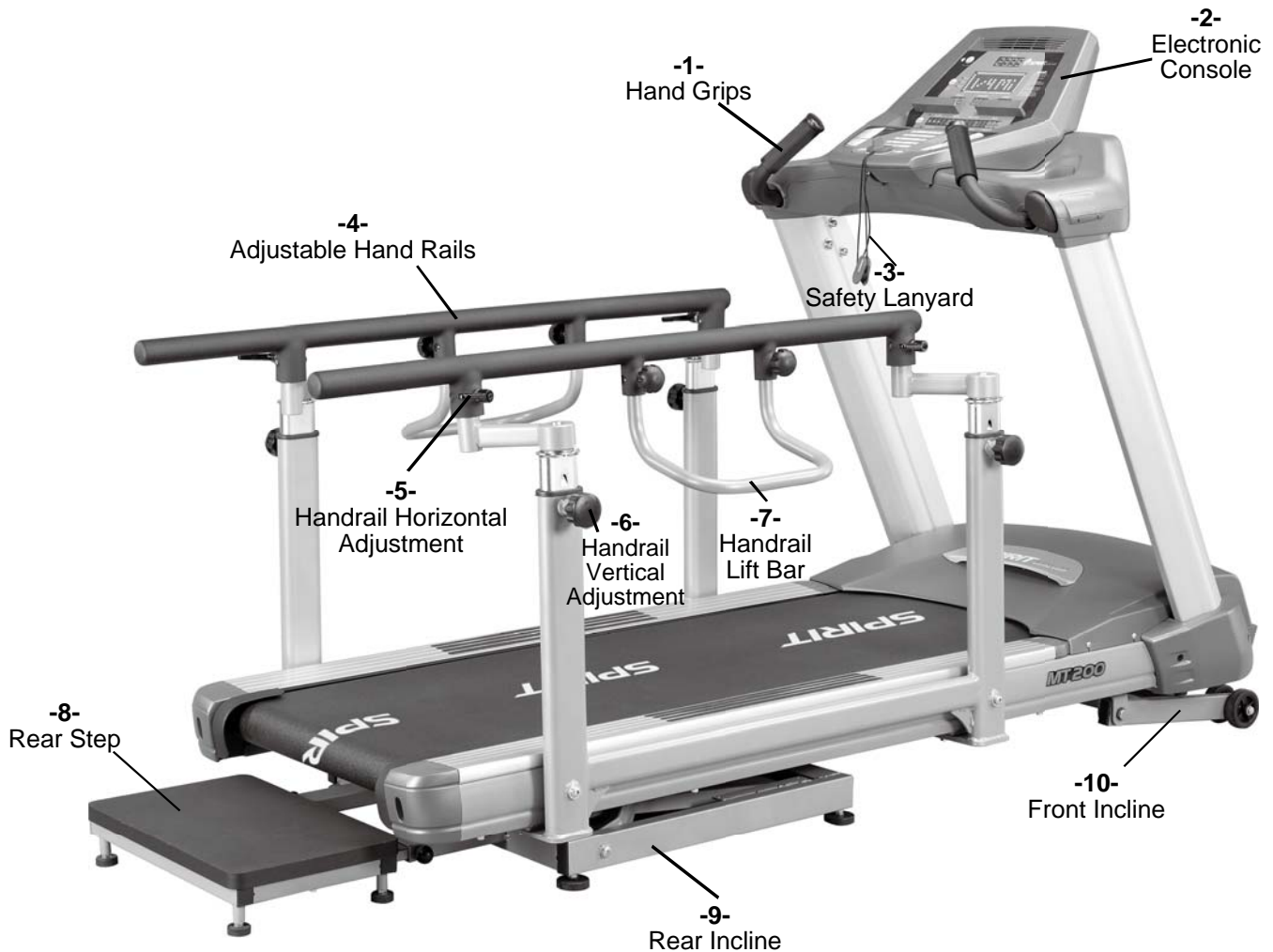

## MT200 – Rehabilitation Treadmill

### Parts and Adjustments:

1. Hand Grips
2. Electronic Console
3. Safety Lanyard
4. Adjustable Hand Rails
5. Handrail Horizontal Adjustment
6. Handrail Vertical Adjustment
7. Handrail Lift Bar
8. Rear Step
9. Rear Incline
10. Front Incline

The Spirit MT200 is an easy product to set up and use, from the adjustments to the intuitive interface. This section explains how to set up, adjust and operate your MT200 from Spirit Medical Systems Group.

## Leveling the MT200:

- Once the MT200 is assembled, and placed on a flat level floor, it may be necessary to adjust the four leveling glides on the bottom of the rear incline unit to ensure proper stability of the MT200. Use a 1/2" wrench to loosen the top nut of the leveler. Adjust the levelers by hand as necessary to remove any wobble in the unit. Then tighten the top nut against the bottom of the stabilizer tube. Make sure the bottom nut remains cinched against the leveling foot.

## Connecting to A.C. Power:

- The MT200 A.C. mains input connector is located in the front of the unit. The input module has an input connector for the line cord, a power switch and a 20 amp circuit breaker. Turn the power switch to off when the MT200 is not in use.

## Hand Rail Adjustments



**Vertical Adjustment**



**Horizontal Adjustment**



**Lift Bar**

## Adjusting the hand rail vertical position:

- **To Lift:** Turn both the left and right vertical adjustment knobs counterclockwise one or two rotations. Then just grab the lift bar and pull up. The locking pins in the knobs will automatically ratchet into the indexing holes in the tubes. Tighten the knobs when desired position is set. There is a numbered scale on the tubes for repeatable settings.
- **To Lower:** Loosen the two knobs and then pull them out and rotate slightly until the knob remains out on its own. The pin should now be disengaged from the tube and you can use the lift bar to lower the rails. Lower the rail past the position you desire and rotate the knob again so the pin can engage the holes in the tube. Now lift the rails to the desired position and lock the knob.

## Adjusting the hand rail horizontal position:

- Turn both the left and right levers counterclockwise one rotation. Move the rails to the desired position and re-lock the levers. There are numbered scales on the tubes for repeatable settings. The levers may be blocked by the rotating tube when position is changed. The levers can be repositioned by pulling out and rotating them to a new position, allowing tightening.

**Lift Bar:**

- The lift bar will make raising and lowering the hand rails easier. You can remove the lift bars for better patient access by loosening the locking knobs. Hold the bar with one hand and loosen the knobs with the other so the lift bar does not suddenly fall to the floor.

**Rear Step:**

- Additional step lowers the step-up height to 4 inches. To install or remove the step easily there are two removable pins located under the rear of the treadmill. Be sure these two pins are in place before using.

- **MT200 Electronic Console:**



## Power on

When initially powered on the console will perform an internal self-test. During this time all the lights will turn on for a short time. The message window will display a software version (i.e. VER 1.0) and the distance window will display an odometer reading indicating how many virtual miles (or Kilometers) the treadmill has gone. The time window displays how many hours the treadmill has been used.

The odometer will remain displayed for only a few seconds then the console will go to the start up display, also known as Idle Mode. The dot matrix display will be scrolling through the different program profiles and the message window will be scrolling the start up message. You may now begin to use the MT200.

The console will automatically power down after 20 minutes of inactivity. Press any key to wake the console up again. To disable this function so console always remains powered on see Maintenance section on page 38. Always turn off the main power switch when the MT200 is not in use.

## **Console Operation:**

### **1. Set Up**

The Set Up key function will allow you to enter patient data and customize the settings of the MT200. When the Set Up key is pressed the first option in the menu appears. Use the up/down arrows to scroll through the menu and press the enter key to select an option.

#### **Set Up menu:**

1. Patient Data:
  - **Age:** used in Vo2 and heart rate programs.
  - **Gender:** used in Vo2 program.
  - **Weight:** used in METs and Calorie calculations and Vo2 program.
  - **Height:** used in the Symmetry program.

### **2. Quick Start**

This is the quickest way to start an exercise session. After the console powers up you just press the Start key to begin; this will initiate the Quick Start mode. In Quick Start the speed will be set to zero until the user adjusts the speed. Time will count up from zero, all workout data will start to accrue and the speed and incline may be adjusted manually by pressing the Up or Down key. The dot matrix will display a speed level. As you increase the speed more rows will light indicating a harder workout.

The dot matrix has 24 columns of lights and each column represents 1 minute in the Quick Start program (time per column can be modified in other programs). At the end of the 24<sup>th</sup> column (or 24 minutes of work) the display will wrap around and restart at the first column again.

### **3. Basic information**

The **Dot Matrix Display** is used for displaying graphic feedback and has three basic displays for most programs. When you begin a program the dot matrix will display a speed profile. To the left of the dot matrix there is a key labeled Display. Pressing this key will switch the display to show an incline grade and then a track. When the LEDs are blinking the graph will scan through the three displays.

The four **Data Windows** display:

- **Time:** Program time remaining, or elapsed time in quick start mode.
- **Incline Grade:** Front incline range 0 to 15 %. Rear Incline range 0 to minus 10%
- **Distance:** Displayed in miles or kilometers, selected in engineering mode (see page 38).
- **Speed:** Displayed in mph or kph. Range from minus 3 mph (5 kph) to plus 10 mph (16 kph) in 0.1 increments. True zero speed provided by a mechanical brake whenever motor is idle.

The **Message Window** is the main display for programming instructions and relevant measurements during a program. The measurement data shown varies depending on the program. Measurements include:

- **Pulse:** Heart rate monitor displayed in beats per minute, from 0 to 240 bpm.
- **METs:** Metabolic equivalent; values of activities range from 0.9 (sleeping) to 23 (running at 22.5 km/h or a 4:17 mile pace).
- **Calories:** Or kilocalorie (kcal), nutritional Calories burned during exercise.
- **Pace:** Displayed as minutes per mile (or kilometer).
- **Step Cadence:** Steps per minute average.
- **Step Length:** Heel strike to heel strike step length in inches or centimeters.
- **Symmetry:** The percentage of difference between the left and right step length.

To the left of the message window is a Display key that allows you to switch the data shown.

Below the Message window is a **Heart Icon** and a **Bar Graph**. Wearing an optional heart rate chest belt transmitter will start the Heart Icon blinking (this may take a few seconds). The Message Window will display your heart rate in beats per minute. The Bar Graph represents the percentage of maximum heart rate. NOTE: Enter the correct age in Set Up for the Bar Graph to be accurate. Refer to Heart Rate section for details about these features.

## 4. Function Keys

The **Stop/Reset** key provides several functions:

- Pressing the Stop/Reset key once during a program will **Pause** the program. To resume the exercise session just press the Start key.
- If the Stop/Reset button is pressed twice during a workout **Ends** the program and a summary of information for the exercise session will be displayed.
- If the Stop/Reset key is held down for 3 seconds the console will perform a complete **Reset**.
- During data entry for a program the Stop/Reset key performs a **Previous Screen** function. This allows you to go back one step in the programming each time you press the Stop/Reset key.

The **Program Keys** may be used to preview each program when in the idle mode. Press each program key to preview the program profile. To begin a program press the corresponding program key and then press the Enter key to select the program.

The program keys also function as a **Number Key Pad** when you are in the data-setup mode. The number for each key is shown below the program name. If you are entering new data such as Time, Age, weight etc., you can use these keys to enter the numbers quickly.

**Forward:** This key sets the belt direction to forward. Forward is the default direction setting when the treadmill is powered on and any time the console is in the idle mode. If the belt is already set in the reverse direction, it will change the direction of the belt to forward. If the belt is moving in reverse when the key is pressed the belt will slow down to zero speed and then speed changes in the forward direction are allowed.

**Reverse:** This key sets the belt direction to reverse if the belt is already set to forward direction. This function only operates in Quick Start or Manual mode. If the belt is moving when the key is pressed the belt will slow down to zero speed then allow speed changes in the reverse direction. The Speed window will show a minus (-) sign indicating the speed is set to reverse.



**Acceleration - Deceleration:** This function adjusts the acceleration and deceleration rate of the walking belt by allowing you to change the amount of time it takes for the belt to change speeds. The adjustment value is in seconds. You can input how many seconds it takes for the belt to change 1 mph of speed. The default setting is 3 seconds, which means the belt will take 3 seconds to go from zero to 1 mph. The range can be set from 1 second to 60 seconds. This function can be disabled in the Engineering mode (see page 38 for engineering mode).

**Incline:** Press this key to return to front incline function if Decline function is active.

**Decline:** Allows operation of the rear deck motor for Decline function. This key only operates in Quick Start or Manual modes. When the function is active the Grade window will show a minus (-) sign indicating the grade is set for decline.

**Zero Percent:** Returns the deck to zero percent when pressed.

## 5. Deck-Lift Program

This program allows you to raise the entire deck parallel to the floor. In this mode the deck, rear step and hand rails can be used for step-up, step-down, stretching and PNF/PTA exercises. Lifting the deck while a patient walks allows the therapist to assist the patient by moving their legs without having to bend over too far.

The Deck-Lift program is also used with the Spirit basic Un-weighting system. Raise the deck and connect the patient's un-weighting harness to the un-weighting system. The Up and Down keys can be used to raise or lower the deck for un-weighting the patient.

- a. Instructions for raising and lowering the deck:
  - i. Press the Deck-Lift key to activate the program.



- ii. The Grade window will display 01 which indicates the first level. The starting height from the step to the deck at level 1 is 5.25 inches (13.34cm). The height will be displayed in the message window. The height from the floor to the step is 4 inches (10 cm).
    - iii. Press the Up and Down keys to raise and lower the deck. There are 30 levels available with each level raising the deck ¼ inch (6.35mm). At level 30 the deck height is 12.5 inches (31.75cm) from the step. Note that the measurements are approximate.
    - iv. In the Deck-Lift program you can press the start key and the treadmill will function normally as if in Manual mode.
    - v. When the Stop key is pressed you will be prompted to confirm the deck will be returned to the lowest level. This ensures that the deck does not automatically lower itself to level one when a patient is connected to the un-weighting system.

## 6. Selecting and customizing programs

When a program is selected you have the option of modifying the settings. If you want to begin without entering new settings just press the Start key. This will bypass the programming of data and take you directly to the start of the program. If you want to change the settings just follow the instructions in the message window. When you start a program the data from the Set Up menu will be used.

### Manual

The Manual program works as the name implies, manually. This means that you control the workload yourself, not the computer. To start the Manual program follow the instructions below or just press the Manual button then the Enter button and follow the directions in the message window.

1. Press the **Manual** key then press the **Enter** key.
2. The message window will prompt you to enter the time for the program. You may enter the time using the Up and Down keys or the numeric key pad then press the Enter key to accept.
3. Now you are finished editing the settings and can begin the program by pressing the Start key. All data calculations will use the patient information from the Set Up function (Set Up key at top left of console).
4. During the Manual program you will be able to scroll through the data in the message window by pressing the **Display key**. You may also switch between the speed, incline or track displays by pressing the Display key adjacent to the dot matrix display.
5. When the program ends you may press Start to begin the same program again or Stop to exit the program, or you can save the program you just completed as the **Facility** program by pressing the Facility key and following the instructions in the message window.

### Preset Programs

The treadmill has two preset exercise programs that have been designed for a variety of goals. The initial built-in level of difficulty for each program is set to a relatively easy level. You may adjust the level of difficulty (Max speed) for each program before beginning.

The profiles shown in the dot matrix are merely pictures of the whole profile and will not change in size when the speed keys are pressed. When setting up a program you will enter the maximum speed setting for the peak of the profile. During the program the speed levels will change as the profile progresses. When the up key is pressed to request more speed the profile picture will not change, but the speed will increase. Pressing the speed keys actually change the peak level of the program not the current segment speed. You may need to change the peak setting several times by pressing the speed key before the current segment increases.

### Preset programs speed and incline settings

The preset program speed and incline levels are shown in the chart below. The Speed numbers shown in the chart indicate a percentage of the top speed of the program.

Prog	SEG	Warm up	1	2	3	4	5	6	7	8	9	10	11	12	13	14	15	16	17	18	19	20	21	22	23	24	Cool down		
Plateau	Speed	20	30	40	50	60	60	70	80	100	100	100	100	100	100	100	100	100	100	100	100	100	80	70	60	50	40	30	20
	Incline	0	0	0	0	0	0	0	0	0	0	0	0	0	0	0	0	0	0	0	0	0	0	0	0	0	0	0	0
Interval	Speed	20	30	40	50	60	60	70	80	100	60	60	70	80	100	60	70	100	60	70	80	70	60	60	50	40	30	20	
	Incline	0	0	0	0	1	2	3	5	6	2	3	5	6	7	2	3	7	2	3	8	2	3	5	4	3	1	0	0



## Programming Preset Programs:

1. Select a program then press the enter key to begin customizing the program settings, or just press the start key to begin the program with the default settings. All data calculations will use the patient information from the Set Up function (Set Up key at top left of console).
2. After selecting a program, press enter to set the program time. The **Time** window will blink with the default value of 20 minutes. You may use any of the up/down keys to adjust the time. After adjusting the time, press enter. (Note: You may press start at any time during the programming to begin with only settings you have modified at that point).
3. The **Speed** window will now be blinking, showing the preset top speed of the selected program. Use the Up/Down keys to adjust, and then press enter. Each program has various speed changes throughout; this allows you to limit the highest speed the program will attain during your workout.
4. Now press the Start key to begin your workout.
5. There will be a 3 minute warm-up to begin. You can press the start button to bypass this and go straight to the workout. During the warm-up the clock will count down from 3 minutes.

## Facility Program

The Facility program allows you to build and save a custom program. You can build your own custom program by following the instructions below or you can save any other preset program you complete as a custom program. The Facility program allows you to further personalize it by adding your facility name.

### Designing and saving a new program:

1. Press the **Facility** key. The message window will show a welcome message; if you had previously saved a program the message will contain the name you gave it. Then press the **Enter** key to begin programming.
2. When you press enter, the message window will show "Name – A", if there is no name saved. If the name "Custom Workout" had been previously saved the message window will show "Name – Custom Workout" and the C in Custom will be blinking. If there is a name saved you can change it or you may press the Stop key to keep the name and continue to the next step. If you want to enter a name use the Up and/or the Down key to change the first letter then press Enter to save the first letter and continue to the next letter. When you have finished entering the name press the Stop key to save the name and continue to the next step.
3. The message window will ask you to enter an **Age**. You may enter an Age, using the Up and Down keys or the numeric key pad, then press the Enter key to accept the new number and proceed on to the next screen.
4. You are now asked to enter a **Weight**. You may adjust the Weight number using the Up and Down keys or the numeric key pad then press enter to continue.

5. Next is **Time**. You may adjust the Time and press enter to continue.
6. Now you are asked to adjust the **Max Level**. This is the peak exertion level you will experience during the program. Adjust the level and then press enter.
7. Now the first column will be blinking and you are asked to adjust the level for the first segment of the workout. When you finish adjusting the first segment, or if you don't want to change, then press enter to continue to the next segment.
8. The next segment will show the same level as the previously adjusted segment. Repeat the same process as the last segment then press enter. Continue this process until all twenty four segments have been set.
9. The message window will then tell you to press enter to save the program. After saving the program the message window says "New program saved" then will give you the option to Start or modify the program. Pressing Stop will exit to the start up screen.
10. During the Facility program you will be able to scroll through the data in the message window by pressing the adjacent **Display** key.

#### **Running a saved program:**

1. Press Facility key then Enter
2. Enter Time then press enter. Then press start to begin program.

## Vo2 Test

The VO2 test is based on the Gerkin protocol, also known as the fireman's protocol, and is a sub-max Vo2 (volume of oxygen) test. The test will increase speed and elevation alternately until 85% of Max heart rate is attained. The time it takes the heart rate to reach 85% determines the test score (Vo2 max) as shown in the chart below.

Stage	Time	Speed	Grade	VO2 Max
1	0 to 1:00	4.5mph	0%	31.15
2.1	1:15	4.5mph	2%	32.55
2.2	1:30	4.5mph	2%	33.6
2.3	1:45	4.5mph	2%	34.65
2.4	2:00	4.5mph	2%	35.35
3.1	2:15	5.0mph	2%	37.45
3.2	2:30	5.0mph	2%	39.55
3.3	2:45	5.0mph	2%	41.3
3.4	3:00	5.0mph	2%	43.4
4.1	3:15	5.0mph	4%	44.1
4.2	3:30	5.0mph	4%	45.15
4.3	3:45	5.0mph	4%	46.2
4.4	4:00	5.0mph	4%	46.5
5.1	4:15	5.5mph	4%	48.6
5.2	4:30	5.5mph	4%	50
5.3	4:45	5.5mph	4%	51.4
5.4	5:00	5.5mph	4%	52.8
6.1	5:15	5.5mph	6%	53.9
6.2	5:30	5.5mph	6%	54.9
6.3	5:45	5.5mph	6%	56
6.4	6:00	5.5mph	6%	57
7.1	6:15	6.0mph	6%	57.7
7.2	6:30	6.0mph	6%	58.8
7.3	6:45	6.0mph	6%	60.2
7.4	7:00	6.0mph	6%	61.2
8.1	7:15	6.0mph	8%	62.3
8.2	7:30	6.0mph	8%	63.3
8.3	7:45	6.0mph	8%	64
8.4	8:00	6.0mph	8%	65
9.1	8:15	6.5mph	8%	66.5
9.2	8:30	6.5mph	8%	68.2
9.3	8:45	6.5mph	8%	69
9.4	9:00	6.5mph	8%	70.7
10.1	9:15	6.5mph	10%	72.1
10.2	9:30	6.5mph	10%	73.1
10.3	9:45	6.5mph	10%	73.8
10.4	10:00	6.5mph	10%	74.9
11.1	10:15	7.0mph	10%	76.3
11.2	10:30	7.0mph	10%	77.7
11.3	10:45	7.0mph	10%	79.1
11.4	11:00	7.0mph	10%	80

### **Before the test:**

- Make sure you are in good health; check with your physician before performing any exercise if you are over the age of 35 or persons with pre-existing health conditions.
- Make sure you have warmed up and stretched before taking the test.
- Do not take in caffeine before the test.

### **Fitness test programming:**

1. Press the VO2 key and press enter.
2. The message window will ask you to enter your **Age**. You may adjust the age setting, shown in the Incline window, using the Up and Down keys then press the Enter key to accept the new number and proceed on to the next screen.
3. You are now asked to enter your **Weight**. You may adjust the weight setting, shown in the Distance window, using the Up and Down keys then press enter to continue.
4. Now press Start to begin the test.

### **During the test:**

- The console must be receiving a steady heart rate for the test to begin. You may wear a heart rate chest strap transmitter.
- The test will start with a 3 minute warm-up at 3 MPH (4.8 kph) before the actual test begins.
- The data shown during the test is:
  - a. **Time** indicates total elapsed time
  - b. **Incline** in percent grade
  - c. **Distance** in Miles or Kilometers depending on preset parameter.
  - d. **Speed** in MPH or KPH depending on preset parameter.
  - e. **Target Heart Rate** and **Actual Heart Rate** are shown in the message window.

### **After the test:**

- Cool down for about one to three minutes.
- Take note of your score because the console will automatically return to the start-up mode after a few minutes.

**What the score indicates:**

**VO2max Chart for males and very fit females**

	18-25 years old	26-35 years old	36-45 years old	46-55 years old	56-65 years old	65+ years old
excellent	>60	>56	>51	>45	>41	>37
good	52-60	49-56	43-51	39-45	36-41	33-37
above average	47-51	43-48	39-42	35-38	32-35	29-32
average	42-46	40-42	35-38	32-35	30-31	26-28
below average	37-41	35-39	31-34	29-31	26-29	22-25
poor	30-36	30-34	26-30	25-28	22-25	20-21
very poor	<30	<30	<26	<25	<22	<20

**VO2max Chart for females and de-conditioned males**

	18-25 years old	26-35 years old	36-45 years old	46-55 years old	56-65 years old	65+ years old
excellent	56	52	45	40	37	32
good	47-56	45-52	38-45	34-40	32-37	28-32
above average	42-46	39-44	34-37	31-33	28-31	25-27
average	38-41	35-38	31-33	28-30	25-27	22-24
below average	33-37	31-34	27-30	25-27	22-24	19-22
poor	28-32	26-30	22-26	20-24	18-21	17-18
very poor	<28	<26	<22	<20	<18	<17

## Symmetry

The Symmetry program provides basic gait information and a feedback graph. The program will measure the left and right step length and calculates the symmetry index. The message window will display the user's Cadence, Left and Right step length in inches (or centimeters) and Symmetry index.

The Dot Matrix display will show a graph indicating step symmetry so the user has a visual feedback to aid in improving their gait. If the user has a longer step length with their left leg the graph will increase in size on the left of the dot matrix as shown below.

When the program ends, either by the set time reaching zero or pressing stop twice at any time during the program, a summary is shown in the message window. The summary gives the average cadence, step lengths and average symmetry for the amount of time the user walked.

1. Press the Symmetry key then press the **Enter** key.
2. The message window will prompt you to enter the **Time** for the program. You may enter the time using the Up and Down keys or the numeric key pad then press the Enter key to accept and proceed to the next screen.
3. Now you are finished editing the settings and can begin by pressing the Start key. All data calculations will use the patient information from the Set Up function (Set Up key at top left of console).
4. During the program you will be able to scroll through the data in the message window by pressing the **Display** key.
5. When the program ends you may press Start to begin the same program again or Stop to exit the program, or you can save the program you just completed as the **Facility** program by pressing the Facility key and following the instructions in the message window.

### Biofeedback Graph:

Below is a sample picture showing the symmetry graph. In the message window there is an average step cadence, left and right step length and symmetry measurements. In the example below the step length numbers shown indicate that the left leg is stepping longer than the right leg, 26 vs. 15 inches. The graph reflects the longer stride of the left leg. If the step length was even only two dots would be lit on the bottom center of the graphic screen.



Note: For some types of gaits it may be possible that the left/right data can be displayed in reverse. If this occurs press the Symmetry program key to flip the display.

# Using a Heart Rate Transmitter

\*NOTE: The chest strap transmitter is not a standard part, but is a separate purchase. A chest strap transmitter may be purchased from Spirit. Most transmitters that operate at 5kHz frequency will also work.

How to wear your wireless chest strap transmitter:

1. Attach the transmitter to the elastic strap using the locking parts.
2. Adjust the strap as tightly as possible as long as the strap is not too tight to remain comfortable.
3. Position the transmitter with the logo centered in the middle of your body facing away from your chest (some people must position the transmitter slightly left of center). Attach the final end of the elastic strap by inserting the round end and, using the locking parts, secure the transmitter and strap around your chest.
4. Position the transmitter immediately below the pectoral muscles.
5. Sweat is the best conductor to measure very minute heart beat electrical signals. However, plain water can also be used to pre-wet the electrodes (2 black square areas on the reverse side of the belt and either side of transmitter). It's also recommended that you wear the transmitter strap a few minutes before your work out. Some users, because of body chemistry, have a more difficult time in achieving a strong, steady signal at the beginning. After "warming up", this problem lessens. As noted, wearing clothing over the transmitter/strap doesn't affect performance.
6. Your workout must be within range - distance between transmitter/receiver – to achieve a strong steady signal. The length of range may vary somewhat but generally stay close enough to the console to maintain good, strong, reliable readings. Wearing the transmitter immediately against bare skin assures you of proper operation. If you wish, you may wear the transmitter over a shirt. To do so, moisten the areas of the shirt that the electrodes will rest upon.

*Note: The transmitter is automatically activated when it detects activity from the user's heart. Additionally, it automatically deactivates when it does not receive any activity. Although the transmitter is water resistant, moisture can have the effect of creating false signals, so you should take precautions to completely dry the transmitter after use to prolong battery life (estimated transmitter battery life is 2500 hours). If your chest strap has a replaceable battery the replacement battery is Panasonic CR2032.*

## Erratic Operation:

**Caution! Do not use this treadmill for Heart Rate Control unless a steady, solid Actual Heart Rate value is being displayed. High, wild, random numbers being displayed indicate a problem.**

**Areas to look at for interference, which may cause erratic heart rate:**

- (1) Microwave ovens, TVs, small appliances, etc.
- (2) Fluorescent lights.
- (3) Some household security systems.
- (4) Perimeter fence for a pet.
- (5) Some people have problems with the transmitter picking up a signal from their skin. If you have problems try wearing the transmitter upside down. Normally the transmitter will be oriented so the Spirit logo is right side up.
- (6) The antenna that picks up your heart rate is very sensitive. If there is an outside noise source, turning the whole machine 90 degrees may de-tune the interference.
- (7) If there is another person wearing a chest strap within 1 meter, it will interfere.
- (8) *If you continue to experience problems contact your dealer.*

## Heart Rate Program operation

To start the **HR** program follow the instructions below or just press the HR key then the Enter button and follow the directions in the message window.

1. Press the **HR** key then press the **Enter** key.
2. The message window will ask you to enter your **Age**. You may enter your Age, using the Up and Down keys or the numeric key pad, then press the Enter key to accept the new number and proceed on to the next screen.
3. You are now asked to enter your **Weight**. You may adjust the Weight number using the Up and Down keys or the numeric key pad, then press enter to continue.
4. Next is **Time**. You may adjust the Time and press enter to continue.
5. Now you are asked to adjust the **Heart rate Level**. This is the heart rate level you will experience during the program. Adjust the level and then press enter.
6. Now you are finished editing the settings and can begin your workout by pressing the Start key. You can also go back and modify your settings by pressing the Enter key. **NOTE:** At any time during the editing of Data you can press the Stop key to go back one level, or screen.
7. If you want to increase or decrease the workload at any time during the program press the Up or Down key. This will allow you to change your target heart rate at any time during the program.
8. During the HR program you will be able to scroll through the data in the message window by pressing the adjacent **Display key**.
9. When the program ends you may press Start to begin the same program again or Stop to exit the program or you can save the program you just completed as a custom user program by pressing the Facility key and following the instructions in the message window.



# ASSEMBLY INSTRUCTIONS FOR MT200

## 1) Hardware

### STEP 1

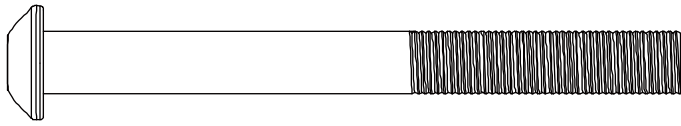

#104-3/8" x 3-3/4" (6PCS)

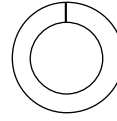

#58-3/8" x 2T x 4H (6PCS)

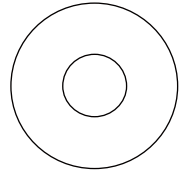

#59-3/8" x 25 x 2T (6PCS)

### STEP 2

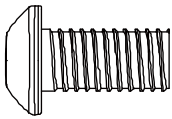

#153-3/8" x 3/4" (6PCS)

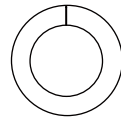

#58-3/8" x 2T x 4H (6PCS)

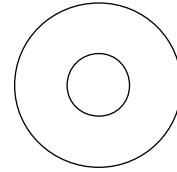

#59-3/8" x 25 x 2T (6PCS)

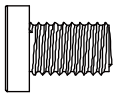

#108-M8 x 12L (6PCS)

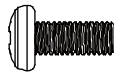

#73-M5 x 12L (4PCS)

### STEP 3



#110-M5 x 10L (2PCS)



#112-M5 x 30L (2PCS)

### STEP 4

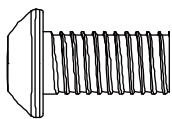

#153-3/8" x 3/4" (8PCS)

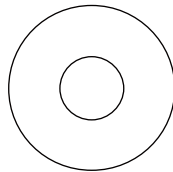

#59-3/8" x 25 x 2T (8PCS)

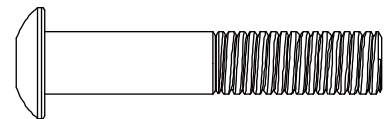

#226-3/8" x 2" (8PCS)

## Step 1: Upright Tubes

- The right side upright tube (19) has the computer cables pre-installed. Lift the tube off the walking surface and attach it to the base frame. You need to gently pull on the computer cables as you align the upright tube into the bracket on the base frame, taking the slack out so the cable does not get pinched between the tube and the base frame. Assemble one 3/8" x 3-3/4" bolt (104), 3/8" split washer (58) and 3/8" flat washer (59) through the top hole in the retaining plate (21), and corresponding top hole in the upright tube, and screw into the base frame. Now install the other two bolts (104) and washers (58 & 59) and hand tighten all three. Do not torque the bolts yet until the upper console frame is installed.
- Install the left upright (18) in the same manner.

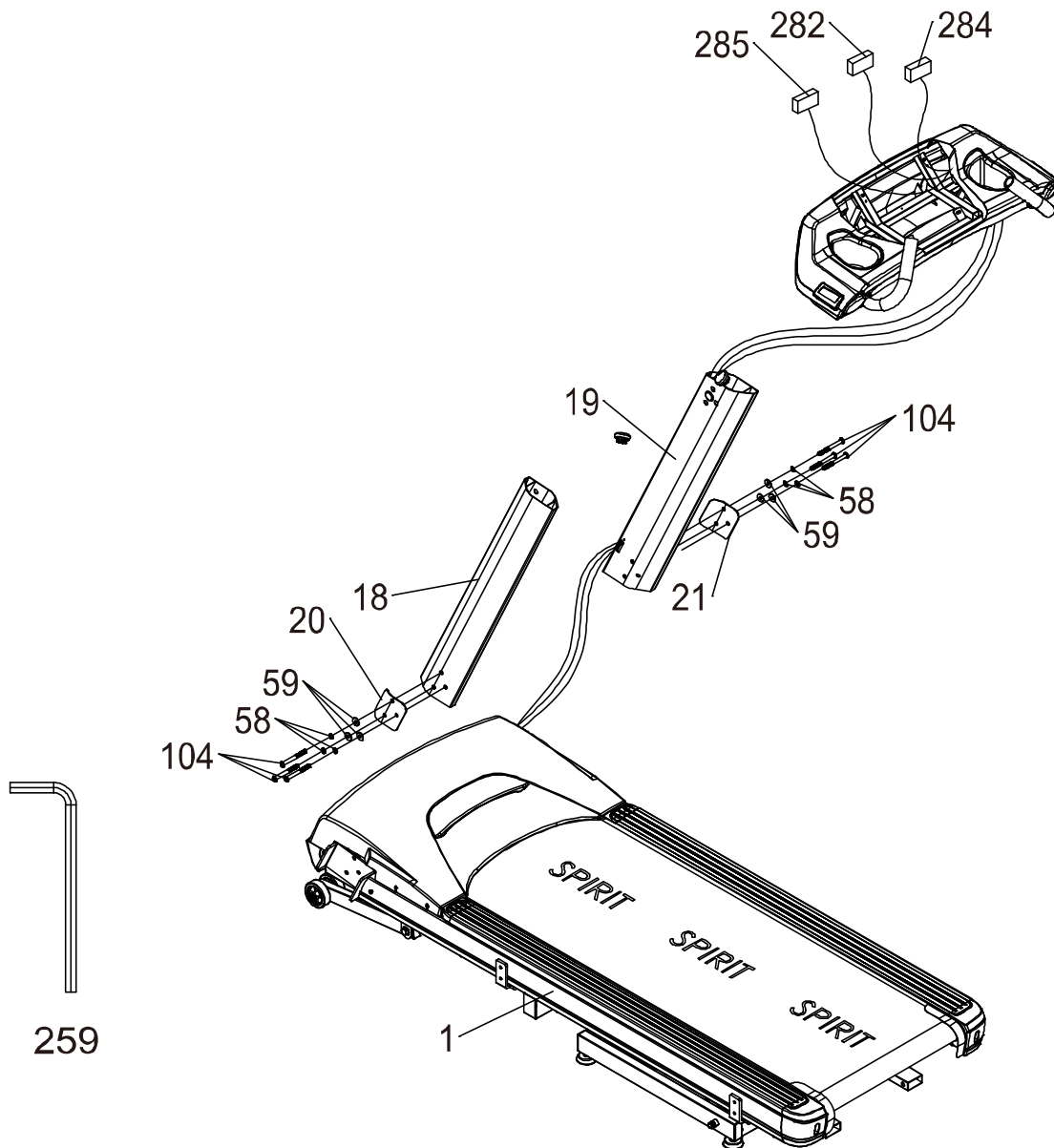

## Step 2: Console Frame Assembly

- Install the two mounting brackets (3 & 4) with the six M8 x 12mm screws (108). Refer to the important instructions on the following page for this step.
- Mount the console frame (5) to the upright tubes (18 & 19) with six 3/8" x 3/4" bolts (153), 3/8" split washers (58) and 3/8" flat washers (59). Be careful not to pinch the computer cables.
- Firmly tighten the six bolts (104) at the bottom of the uprights and install the two end caps (32 & 33) with the four M5 x 12mm screws (73).

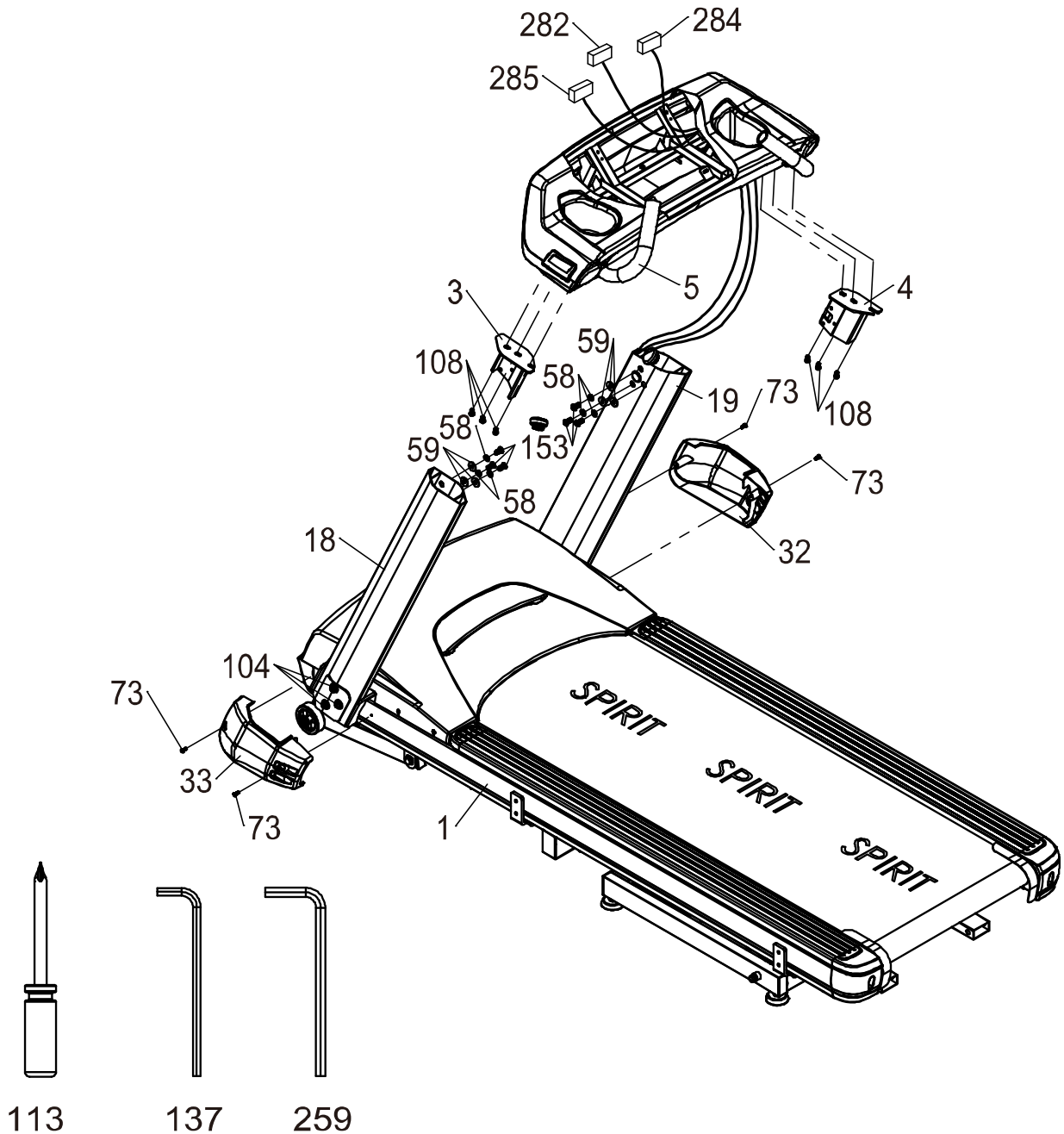

## IMPORTANT ASSEMBLY INSTRUCTION

When assembling the console mounting brackets (Items 3&4) please be sure to slide the brackets all the way towards the back of the console frame before tightening the bolts.

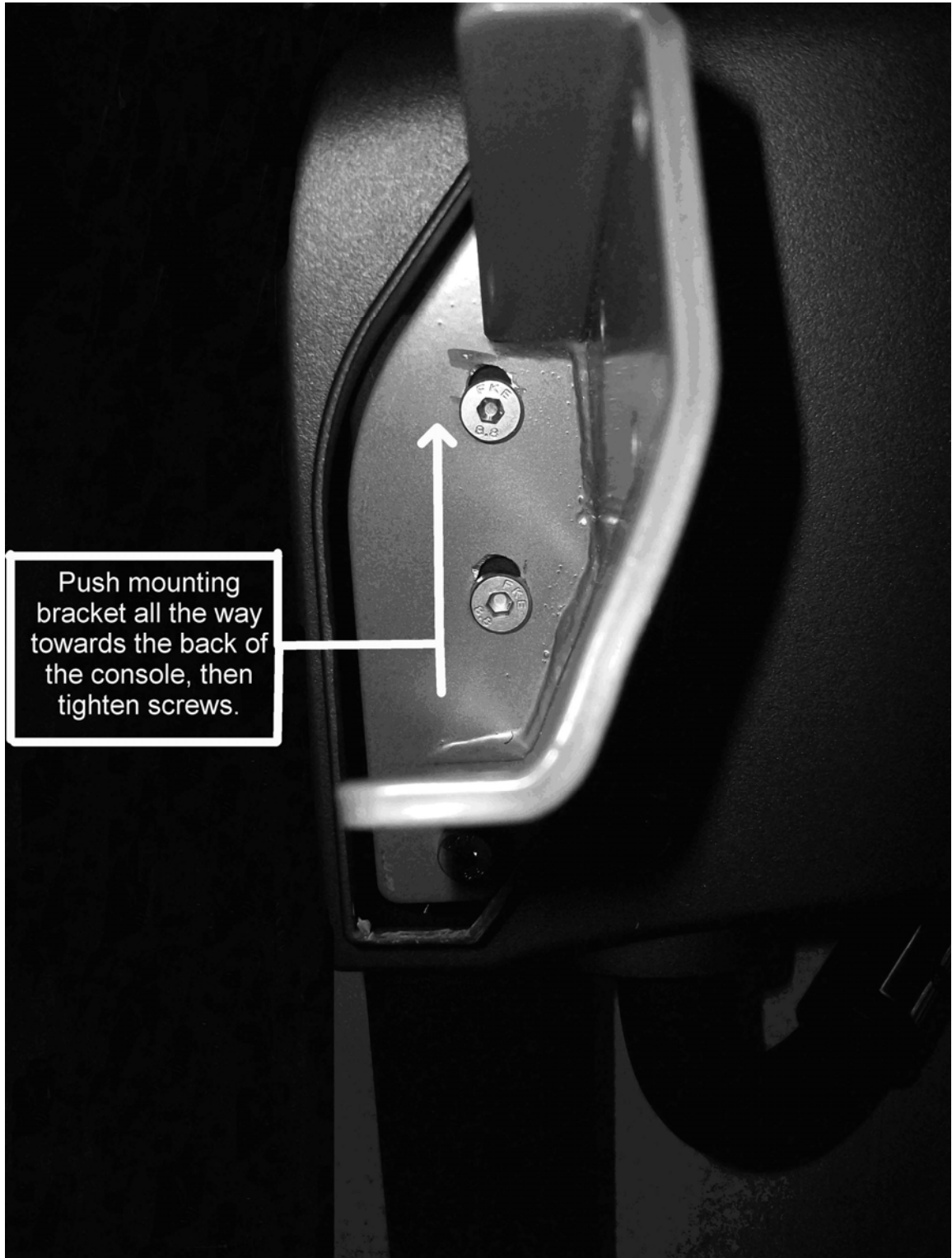

### Step 3: Console Assembly

- Plug all the connectors in back of the console.



- Mount the console (36) to the console frame (5) with two M5 x 30mm screws (112) in the top holes and two M5 x 10mm screws (110) in the bottom holes in the back side of the console frame.

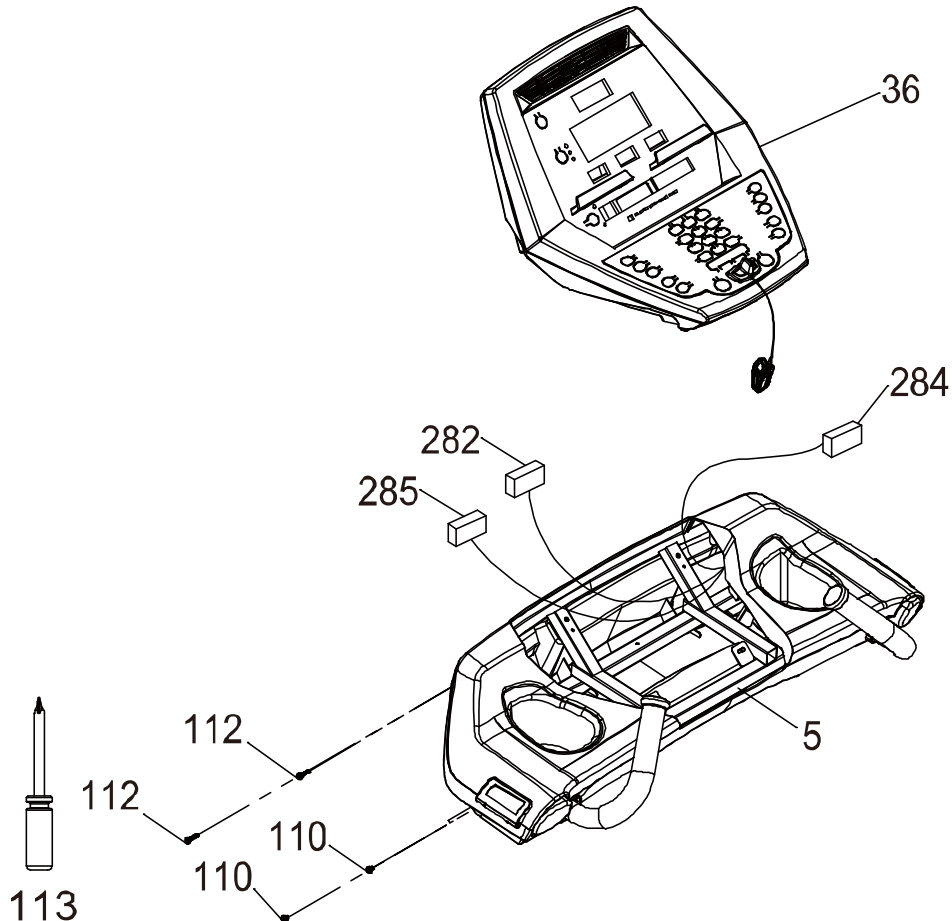

## Step 4: Parallel Bar Handrail Assembly

- Install the eight 3/8" x 3/4" bolts (153) and 3/8" flat washers (59) into the holes on the underside of the frame. Only thread them into the holes two or three turns so the slots in the handrail brackets can slide onto the bolts easily. Slide the handrail onto the bolts and hand-tighten them. Thread the eight 3/8" x 2" bolts (226) into the sides of the handrails. Once all the bolts are installed tighten all of them securely.
- Install the Lift Bars (192) to the parallel bars and secure with the knobs (207).
- Install the rear step (181) by sliding into the receiving tubes under the rear of the deck and secure with the two pins (217). Raising the rear incline may make it easier to line up the holes for the pins.

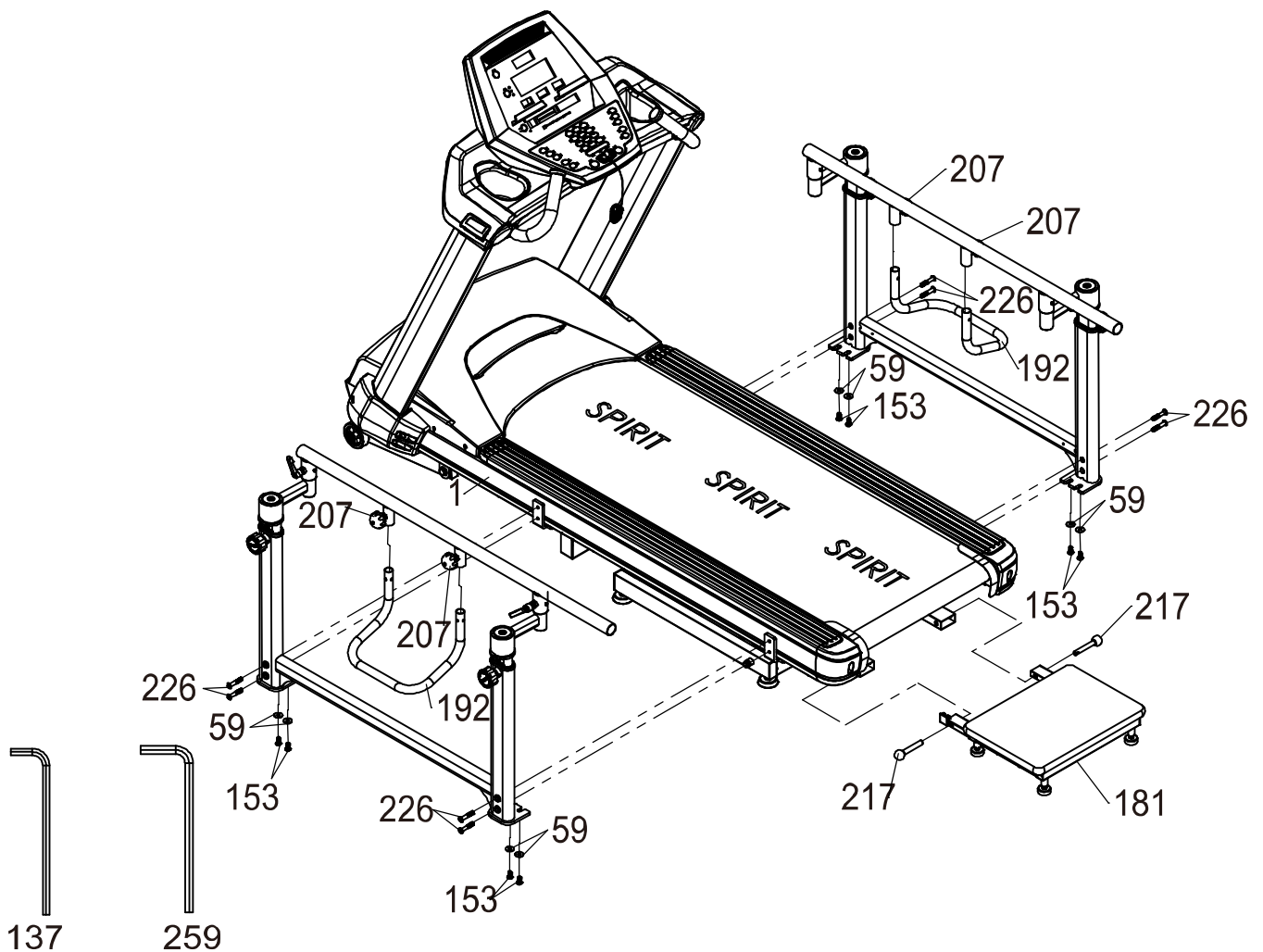



# MT200 Exploded View Drawing

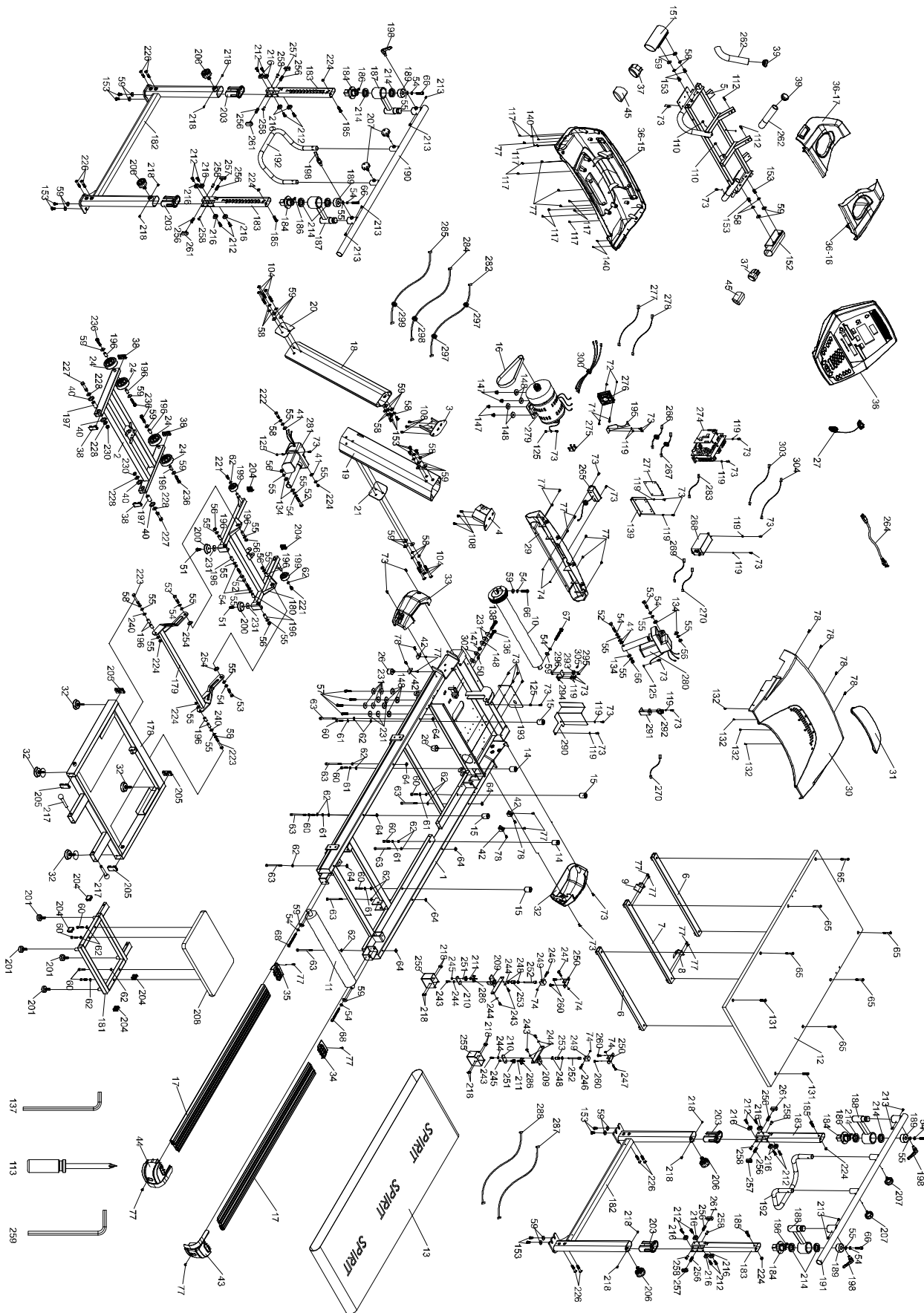

## MT200 Parts List

Dwg #	Description	Qty.
1	Main Frame	1
2	Incline Bracket	1
3	Console Mast Locking Assembly ( L )	1
4	Console Mast Locking Assembly ( R )	1
5	Console Support	1
6	Running Deck Stabilizer Assembly(A)	2
7	Running Deck Stabilizer Assembly(B)	1
8	Belt Guide(R)	1
9	Belt Guide(L)	1
10	Front Roller W/Pulley	1
11	Rear Roller	1
12	Running Deck	1
13	Running Belt	1
14	Cushion A, Middle	2
15	Cushion B, Front & Rear	4
16	Drive Motor Belt, Poly-V	1
17	1380m/m_Aluminum Foot Rail	2
18	Aluminum Upright (L)	1
19	Aluminum Upright (R)	1
20	Upright Fixing Plate(L)	1
21	Upright Fixing Plate(R)	1
24	Ø82 x Ø14 x 35m/m_Transportation Wheel	4
26	Incline Rubber Foot	2
27	800m/m_Safety Key	1
29	Front Motor Cover	1
30	Motor Top Cover	1
31	Top Motor Cover Plate	1
32	Motor Base Cap (R)	1
33	Motor Base Cap (L)	1
34	Foot Rail Cap (R)	1
35	Foot Rail Cap (L)	1
36	Console Assembly	1
36-15	Console Bottom Cover	1
36-16	Console Top Cover(R)	1
36-17	Console Top Cover(L)	1
37	Oval Tube End Cap	2
38	25m/m x 50m/m_Square End Cap	4
39	Hand Pulse End Cap	2



<b>40</b>	Stable Wheel Spacer	4
<b>41</b>	Ø10 × Ø25 × 0.8T_Nylon Washer	4
<b>42</b>	Motor Cover Anchor(D)	4
<b>43</b>	Rear Adjustment Base (R)	1
<b>44</b>	Rear Adjustment Base (L)	1
<b>45</b>	80m/m_Handgrip Foam	2
<b>50</b>	Ground Isolation Cap	1
<b>51</b>	3/8" × 3/4"_Hex Head Bolt	2
<b>52</b>	M10 × P1.5 × 65m/m_Hex Head Bolt	4
<b>53</b>	M10 × P1.5 × 50m/m_Hex Head Bolt	3
<b>54</b>	Ø10 × 1.5T_Split Washer	15
<b>55</b>	Ø10 × Ø19 × 1.5T_Flat Washer	24
<b>56</b>	M10 × P1.5 × 8.0T_Nyloc Nut	7
<b>57</b>	3/8" × UNC16 × 1-1/2"_Socket Head Cap Bolt	4
<b>58</b>	Ø3/8" × 2.0T_Split Washer	19
<b>59</b>	Ø3/8" × Ø25 × 2.0T_Flat Washer	32
<b>60</b>	M8 × P1.25 × 45m/m_Socket Head Cap Bolt	10
<b>61</b>	Ø8× 1.5T_Split Washer	6
<b>62</b>	Ø8 × Ø16 × 1.0T_Flat Washer	20
<b>63</b>	M8 × P1.25 × 110m/m_Socket Head Cap Bolt	8
<b>64</b>	M8 × P1.25 × 6.5T_Square Nut	8
<b>65</b>	M8 × P1.25 × 55m/m_Flat Head Countersink Bolt	6
<b>66</b>	M10 × P1.5 × 40m/m_Socket Head Cap Bolt	5
<b>67</b>	M10 × P1.5 × 80m/m_Socket Head Cap Bolt	1
<b>68</b>	M10 × P1.5 × 100m/m_Socket Head Cap Bolt	2
<b>71</b>	M4 × P0.7 × 35m/m_Phillips Head Screw	2
<b>72</b>	M4 × P0.7 × 5.0T_Nyloc Nut	2
<b>73</b>	M5 × P0.8 × 12m/m_Phillips Head Screw	31
<b>74</b>	M5 × P0.8 × 5.0T_Nyloc Nut	6
<b>76</b>	M3 × 12m/m_Tapping Screw	4
<b>77</b>	M5 × 12m/m_Tapping Screw	23
<b>78</b>	M5 × 15m/m_Sheet Metal Screw	8
<b>104</b>	3/8" × UNC16 × 3-3/4"_Button Head Socket Bolt	6
<b>108</b>	M8 × P1.25 × 12m/m_Socket Head Cap Bolt	6
<b>110</b>	M5 × 10m/m_Phillips Head Screw	2
<b>112</b>	M5 × 30m/m_Phillips Head Screw	2
<b>113</b>	Phillips Head Screw Driver	1
<b>117</b>	Ø3.5× 12m/m_Tapping Screw	10
<b>119</b>	M5 × 1.5T_Split Washer	15
<b>125</b>	M5_Star Washer	4
<b>131</b>	M8 × P1.25 × 35m/m_Flat Head Countersink Bolt	2

132	Ø3 × 8m/m_Tapping Screw	4
134	Ø10 × Ø24 × 3.0T_Nylon Washer	5
136	3/8" × UNC16 × 2" _Socket Head Cap Bolt	1
137	L Allen Wrench	1
138	3/8" × UNC16 × 2-1/4" _Socket Head Cap Bolt	1
139	Inverter Mounting Bracket	1
140	M3 × 10m/m_Sheet Metal Screw	4
147	Ø10 × Ø14 × 14m/m_Bushing	5
148	Ø13 × Ø35 × 5.0T_Nylon Washer	9
151	Left Handgrip	1
152	Right Handgrip	1
153	3/8" × UNC16 × 3/4" _Button Head Socket Bolt	18
178	Frame Base	1
179	Folding Assembly Bracket	1
180	Incline Bracket	1
181	Step Up Frame	1
182	Parallel Bar Frame	2
183	P. Bar Vertical Adjustment Tube	4
184	P. Bar Bearing Inner Race	4
185	3/8" × UNC16 × 1-1/2" _Button Head Socket Bolt	4
186	M5 × 6m/m_Socket Head Cap Bolt	4
187	P. Bar Horizontal Adjustment Arm (L)	2
188	P. Bar Horizontal Adjustment Arm (R)	2
189	P.Bar Horizontal Adj. Cap	4
190	Parallel Handle Bar (L)	1
191	Parallel Handle Bar (R)	1
192	P.Bar Lift Assist Handle	2
193	Fan Back Plate	1
195	Fan Mounting Plate	1
196	Ø14 × Ø10 × 25m/m_Podwer metallurgy Sleeve	14
197	Ø20 × Ø13.4 × 41m/m_Podwer metallurgy Sleeve	2
198	M14 × 17m/m_Seat/Handlebar Adj. Locking Lever	4
199	Ø54 × 25m/m_Transportation Wheel	2
200	Ø60 × 15m/m_Rubber Foot	2
201	Ø37 × 3/8" _Adjustment Foot Pad	4
202	Ø55 × 3/8" _Adjustment Foot Pad	4
203	Plastic Tube Insert	4
204	30m/m × 30m/m_Square End Cap	6
205	30m/m × 60m/m_Square End Cap	4
206	Ø57 × M14_Locking Knob	4
207	3/8" × UNC16 × 25m/m_Brake Tension Knob	4

208	Step Up Platform	1
209	Step Sensor Mounting Plate	2
210	Step Magnet Plate	2
211	Ø10 x 3T x N35_Braking Magnet	2
212	M8 x P1.25 x 25m/m_Flat Head Countersink Bolt	16
213	M5 x P0.8 x 12m/m_Flat Head Socket Screw	8
214	P. Bar Bearing	8
216	PU Wheel	16
217	Step Up Frame Pop Pin	2
218	M4 x P0.7 x 8m/m_Phillips Head Screw	16
221	5/16" x UNC18 x 5/8" _Hex Head Bolt	2
222	3/8" x UNC16 x 1-1/2" _Hex Head Bolt	1
223	3/8" x UNC16 x 3" _Hex Head Bolt	2
224	3/8" x UNC16 x 7.0T _Nyloc Nut	7
226	3/8" x UNC16 x 2" _Button Head Socket Bolt	8
227	1/2" x UNC13 x 2-1/4" _Hex Head Bolt	2
228	Ø13 x Ø26 x 2.0T_Flat Washer	4
230	1/2" x UNC20 x 8.0T_Nyloc Nut	2
231	Ø3/8" x Ø35 x 2.0T_Flat Washer	12
236	3/8" x UNC16 x 1-3/4" _Socket Head Cap Bolt	4
240	Ø14 x Ø20 x 2.0T_Flat Washer	2
243	M5 x 15m/m_Socket Head Cap Bolt	6
244	Ø5 x Ø12 x 1.0T_Flat Washer	6
245	M6 x P1.0 x 5.0T_Nut	2
246	M5 x 30m/m_Socket Head Cap Bolt	2
247	M5 x 35m/m_Socket Head Cap Bolt	2
248	Ø15_C Ring	4
249	U-Joint, Step Sensor	2
250	U-Joint Mounting Plate	2
251	Step Magnet Holder	2
252	Plunger, Step Sensor	2
253	Linear Bearing, Step Sensor	2
254	Bushing, Incline Frame	2
255	Cover, Step Sensor Assembly	2
256	Ø13.5 x 30m/m_Spring	8
257	Brake Pad, P. Bar Slide - 1	4
258	M6 x 19m/m_Nut	8
259	6mm Allen Wrench	1
260	M6 x 20m/m_Button Head Socket Bolt	4
261	Brake Pad, P. Bar Slide - 2	4

<b>262</b>	EVA Foam for Rail Strap	2
<b>264</b>	Power Cord	1
<b>265</b>	A.C. Input Module	1
<b>266</b>	200m/m_Connecting Wire (White)	1
<b>267</b>	200m/m_Connecting Wire (Black)	1
<b>268</b>	A.C. Power Filter	1
<b>269</b>	150m/m_Connecting Wire (White)	1
<b>270</b>	150m/m_Connecting Wire (Black)	2
<b>271</b>	Lower Control Board	1
<b>274</b>	Inverter, A.C. Motor	1
<b>275</b>	Encoder, A.C. Motor	1
<b>276</b>	Fan, Motor Cooling	1
<b>277</b>	500m/m_Motor Fan Connecting Cable (Black)	1
<b>278</b>	500m/m_Motor Fan Connecting Cable (White)	1
<b>279</b>	Drive Motor	1
<b>280</b>	Front Incline Motor	1
<b>281</b>	Rear Incline Motor	1
<b>282</b>	Inverter Signal Cable, 2100m/m	1
<b>283</b>	Inverter to LCB Cable, 800m/m	1
<b>284</b>	Rear Incline Cable, 2100m/m	1
<b>285</b>	RS-485 Communication Cable	1
<b>286</b>	Step Sensor Board	2
<b>287</b>	Step Sensor Cable, Right	1
<b>288</b>	Step Sensor Cable, Left	1
<b>290</b>	Back Plate	1
<b>291</b>	Plate	1
<b>292</b>	Breaker	1
<b>293</b>	Grounding Brush	1
<b>294</b>	Brush Holder	1
<b>295</b>	M3 x 10L_Phillips Head Screw	2
<b>296</b>	M3 x 2.5T_Luck Nut	2
<b>297</b>	Ferrite Core(29m/m)	2
<b>298</b>	Ferrite Core(21.4m/m)	1
<b>299</b>	Ferrite Core(30m/m)	1
<b>300</b>	80m/m_Connecting Cable Of Motor	1
<b>302</b>	Ø16 x Ø35 x 1T_Flat Washer	2
<b>303</b>	300m/m_Connecting Wire (White)	1
<b>304</b>	300m/m_Connecting Wire (Black)	1
<b>305</b>	Ø5.2 x 0.4T x 14.5L_Constrict Spring	1

## Maintenance:

**Belt and Deck** - Your treadmill uses a very high-efficient low-friction deck and belt. Performance is maximized when the bed is kept as clean as possible. Use a soft, damp cloth or paper towel to wipe the edge of the belt and the area between the belt edge and frame. Also reach as far as practical directly under the belt edge. This should be done once a month to extend belt and deck life. Use water only - no cleaners or abrasives. A mild soap and water solution along with a nylon scrub brush will clean the top of the textured belt. **Allow the belt to dry before using.**

**General Cleaning** - Dirt, dust, and carpet fibers can block air inlets and accumulate on the running belt. On a monthly basis: vacuum underneath your treadmill to prevent buildup. Once a year, you should remove the motor hood and vacuum out dirt that may accumulate. **UNPLUG POWER CORD BEFORE THIS TASK.**

## BELT ADJUSTMENTS:

**Tread-belt Tension Adjustment** - Adjustment must be made from the rear roller. The adjustment bolts are located at the end of the step rails in the end caps, as noted in diagram below.

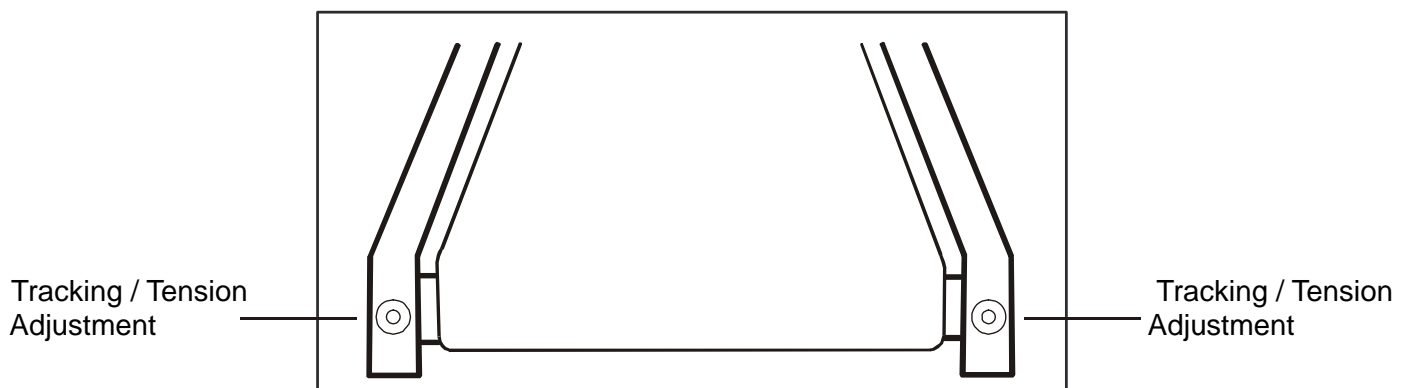

**Note:** Adjustment is through small hole in the end cap.

Tighten the rear roller bolts only enough to prevent slippage at the front roller. Turn both tread-belt tension adjustment bolts with a 10mm allen wrench in increments of 1/4 to 1/2 turn each and inspect for proper tension by walking on the belt at a low speed, making sure the belt does not slip. Keep tensioning the bolts until the belt stops slipping.

- **If you feel the belt is tight enough, but it still slips, the problem may be a loose Motor drive belt under the front motor cover.**

**DO NOT OVERTIGHTEN** – Over tightening will cause belt damage and premature bearing failure.

## TREADBELT TRACKING ADJUSTMENT:

The performance of your treadmill is dependent on the frame running on a reasonably level surface. If the frame is not level, the front and back roller cannot run parallel, and constant belt adjustment may be necessary.

The treadmill is designed to keep the tread-belt reasonably centered while in use. It is normal for some belts to drift near one side while the belt is running with no one on it. After a few minutes of use, the tread-belt should have a tendency to center itself. If, during use, the belt continues to move toward one side, adjustments are necessary.

## TO SET TREADBELT TRACKING:

Use a 10mm Allen wrench to adjust the rear roller. Make tracking adjustments from the **left** side only. Set belt speed at approximately 2 to 3 mph.

Remember, a small adjustment can make a dramatic difference!

Turn the bolt clockwise to move the belt to the right. Turn the bolt only a 1/4 turn and wait a few minutes for the belt to adjust itself. Continue to make 1/4 rotation turns until the belt stabilizes in the center of the running deck.

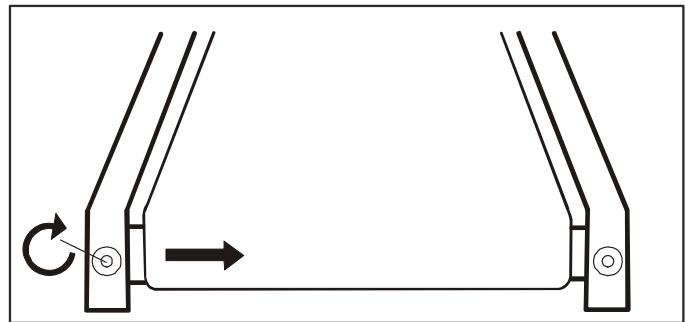

The belt may require periodic tracking adjustment depending on use and walking/running characteristics. Some users will affect tracking differently. Expect to make adjustments as required to center the tread-belt. Adjustments will become less of a maintenance concern as the belt is used. Proper belt tracking is an owner responsibility common with all treadmills.

### ATTENTION:

**DAMAGE TO THE RUNNING BELT RESULTING FROM IMPROPER TRACKING / TENSION ADJUSTMENTS IS NOT COVERED UNDER THE SPIRIT WARRANTY.**

## Maintenance Menu in console software:

The console has built in maintenance/diagnostic software. The software will allow you to change the console settings from English to Metric and turn off the beeping of the speaker when a key is pressed for example. To enter the Maintenance menu (may be called Engineering mode, depending on version) press and hold down the Start, Stop and Enter keys. Keep holding the keys down for about 5 seconds and the message window will display “Engineering mode”. Press the enter button to access the menu below:

### 1. Maintenance Mode

- a. Press and hold the Start, Stop and Enter key at the same time, until the display shows “**ENGINEERING MODE**” (it may say maintenance menu, depending on version). Press the Enter key. You can now scroll through the menu using the up and down keys. Use the Stop key to return to previous menu selection. The menu selections are:
- b. **Key Test** – Press each key to verify it is functioning correctly
- c. **Display test** - Lights all LED lights
- d. **Functions**
  - i. **Sleep** - Turns **SLEEP MODE ON** or **OFF**. When off, display power is always on.
  - ii. **Pause** - Turns **PAUSE MODE ON** or **OFF**. When on, Pause lasts 30 minutes.
  - iii. **Odometer reset** - Reset odometer readings
  - iv. **Units** - Set display to **ENGLISH** or **METRIC** readings
  - v. **Grade Return (GS Mode)** - Turns **GS MODE ON** or **OFF**. Returns the elevation to lowest setting when pause is pressed
  - vi. **Beep** – Turns the speaker (beep sound) on or off.
  - vii. **Service Mode:**
    1. **Incline**
      - a. MW scrolls: “**USE INCLINE KEYS FOR FRONT USE SPEED KEYS FOR REAR**” then switch to VR display below.
      - b. Incline keys operate front motor, speed keys operate rear motor. Hold down up/down key to operate motor, stop when key is released. Motor is allowed to move until limit switch activated.
      - c. MW displays A/D values for both position sensors. Example of the readings F 920 R 70. F=Front incline sensor and R = Rear incline sensor. The readings will be opposite: when at lowest incline the front will show a large number and rear will be small.
    2. **Drive Motor**
      - a. MW displays: “**USE SPEED KEYS TO MOVE MOTOR**”. Each key press increases motor speed 0.1 mph/kph
      - b. MW then shows: RPM 000 AMP 00.0. The sensor reading indicates motor RPM, not belt speed. The AMP is measuring Motor current
    3. **Motor Brake**
      - a. Brake ON (brake coil turned off) (User press enter to turn Brake OFF)
    4. **Step Sensors**
      - a. **Test**
        - i. Use sensor outputs to light DM similar to Symmetry display. This test is only to make sure the sensors are functioning and does not test accuracy. The DM graph shows left and right sensor activity when stepping on the deck. Both sides of the graph will light at the same time, but the side the user steps with would show more segments lit.



## b. Calibration

- i. MW: **START LEFT SIDE**
  - ii. When Start is pressed the MW shows: **AD \_ \_ \_ TGT 65**
  - iii. Speaker will beep slowly when magnet distance is too far, quickly when near and steady when correct.
  - iv. Press enter to continue
  - v. MW: **START RIGHT SIDE**
  - vi. When Start is pressed the MW shows: **AD \_ \_ \_ TGT 65**
  - vii. Speaker will beep slowly when magnet distance is too far, quickly when near and steady when correct.
  - viii. User press enter or stop to end calibration
- e. **Acceleration Key Lock** –MW show “**ACCEL KEY**”, press enter then MW shows “**ACCEL LOCKED**”. This is the default. If the user presses the up or down key the MW shows “**ACCEL UNLOCKED**”. Press enter to exit.
- f. **Speed limit setting** –MW shows “**SPEED LIMIT**”, press enter. The MW shows **Limit 10.0 MPH**. This is the default setting and is the top forward speed of the treadmill.
- i. If the user presses the down key the MW shows **Limit 9.9 MPH**. The top limit can be changed in 0.1 MPH increments.
  - ii. The minimum speed limit setting is 3.0 mph.
- g. **Security** –MW show “**SECURITY**” MW shows “**CHILD LOCK ON**” or **OFF** , Sets the Child Lock function. This function locks out the keypad until a pre-determined key sequence is pressed. Key sequence = Start & Enter held down together until unlocked.

## 2. Factory and Acceleration Settings

- a. Enter the Factory settings; press Start and Speed Fast keys while console is in power up reset. User presses enter
  - i. **UNITS: ENGLISH**
    1. The default setting is English. User can press any up/down arrows to change to Metric. User presses enter.
  - ii. **ADJUST MIN SPEED THEN PRESS ENTER**
    1. Default value is 0.1 mph and can be adjusted up to 0.5mph.
    2. The speed number to be shown in the speed window.
  - iii. **ADJUST MAX SPEED THEN PRESS ENTER**
    1. Default value is 10.0 mph and can be adjusted down to 3.0 mph.
    2. The speed number to be shown in the speed window
  - iv. **ADJUST REVERSE SPEED MAX THEN PRESS ENTER**
    1. Default value is 3.0 mph and can be adjusted down to 1.0 mph and up to 5.0 mph.
  - v. **ADJUST BELT SPEED ACCELERATION TIME PER EACH 1.0 MPH**
    1. The default is 0:03 seconds and will be shown in the Time window.
    2. The time can be adjusted down to 0:01 and up to 1:00 minute
  - vi. **ADJUST BELT SPEED DECELERATION TIME PER EACH 1.0 MPH**
    1. The default is 0:03 seconds and will be shown in the Time window.
    2. The time can be adjusted down to 0:01 and up to 1:00 minute
  - vii. Press Enter for Grade Calibration Or To Exit Hold Stop Key Until Reset.
  - viii. Adjust Max Incline Then Press Enter
    1. The default value is 15 and can be adjusted down to 10
  - ix. Adjust Max Decline Then Press Start to calibrate
    1. The default value is 5 and can be adjusted up to 10
  - x. If Grade calibration is successful the MW shows “Passed” for 3 seconds then exit to idle mode.



## **Error Codes, Messages and Solution/Cause**

### **Error Codes**

E1 Over Current Deck Lube Bad Drive or Motor Check Brake	E12 EPROM RD Check AC Line V Reset Power Bad Drive	E26 Bk Chopper Reset Power Bad Drive
E2 Over Volt Check AC line V	E13 EPROM WR Check AC Line V Reset Power Bad Drive	E27 PG Error Check Motor
E3 Over V Decel Check AC line V Check Brake	E14 Ext Fault Reset Power	E28 Phase Loss Check Wiring Bad Drive
E4 Ground Fault Check wiring Replace Drive	E15 U Phase I Reset Power Bad Drive	E29 I Signl Stop Reset Power Bad Drive
E5 IGBT Fault Check wiring Replace Drive	E16 W Phase I Reset Power Bad Drive	E30 CPU Error Electronic circuit fault
E6 Drive Ovrload Deck Lube Brake locked Bad Drive Bad Motor	E17 HW Fault Reset Power Bad Drive	E31 Fan Drive Fan Bad
E7 Thrm Ovrload Brake locked Deck Lube Bad Drive Bad Motor	E18 IGBT O-Heat Bad Drive Fan Dirty Heat Sink	E32 Analog In Check Wiring Bad Drive
E8 Over Torque Brake locked Deck Lube Bad Drive Bad Motor	E19 Ambient Temp Air Vent Blocked Bad Fan	E33 Over Trque Mechanical Deck Lube Brake Bad Motor Bad Drive
E9 Over I Speed Check Brake Deck Lube Bad Drive Bad Motor	E20 Inrush Fault Reset Power Bad Drive	E34 Thrm Ovrld 2 Brake locked Deck Lube Bad Drive Bad Motor
E10 Over I Accel Deck Lube Bad Drive Bad Motor	E21 In Sig Lost Check Wiring Bad Drive	E35 Motor Sel Motor Wiring
E11 Over I Decel Deck Lube Bad Drive	E22 RS-485 Flt Check Wiring	E36 LV Bus Run Check AC Line V Bad Drive
	E23 PID Error Check Wiring Chk Para Setting	E37 LV Bus Check AC Line V Bad Drive
	E24 PU Comm Bad Drive	E38 Ext BB Para Settings
	E25 Auto Tune Chk Motor wires Reset Power	E41 Incline Err E42 Decline Err

## Specifications:

**REF** MT200

**Set-Up Dimensions:** Length: 94" (239 cm) with rear  
Width: step. 36" (91.4 cm)  
Height: 56.5" (143.5cm)

**Product Weight:** 514.8 Lbs. (234 Kgs)

**Patient Weight Capacity:** 440 Lbs. (200 Kgs.)

**Power: Fuse Rating:** 115 Volts A.C., 20 Amps, 60 Hz.

Circuit Breaker: AC 125V, 20A  
Mode of Tripping: Thermal  
Operating Speed: 0.25~3.0 sec.  
Breaking Capacity: 1000A, 125 VAC

### Fuse on Inverter:

Voltage: 125 Vac  
Current: 1A  
Operating Speed: 0.4~1.0 sec.  
Breaking Capacity: 50A, 125 Vac  
Size: 2.65mm X 7.1mm

**Speed:** Forward: 0.0 to 10.0 mph (0.0 to 16 kph)  
Reverse 0.0 to 3.0 mph (0.0 to 5 kph)

**Incline:** Front: 0 to 15% Grade  
Rear: 0 to 10% Grade

**Readouts:** Time, Grade, Distance, Speed, Pause, METs, Calories, Pace, Cadence, Left and Right Step Length, Symmetry Index

**Certifications:** TUV listed to ANSI/AAMI ES60601-1:2005+A2 (R2012) +A1, CAN/CSA-C22.2 No. 60601-1:14, CE conformity to EN 60601-1 EMC, Compliance to EN 60601-1-2

**Classification:** Class I, Type B, ordinary equipment, continuous operation. This product is classed as ordinary equipment according to IEC/EN/UL60601-1 and is NOT protected against the ingress of water.

**Disposal:** Reference should be made to local regulations concerning the disposal of this product at the end of useful life.



Dyaco International Inc.  
12F, No.111, Songjiang  
Rd. Taipei 104, Taiwan  
R.O.C.



c U S

## Guidance and manufacturer's declaration – electromagnetic compatibility

The MT 200 is intended for use in the electromagnetic environment specified below. The customer or the user of the MT 200 should assure that it is used in such an environment.

Emissions test		Compliance		Electromagnetic environment – guidance
RF emissions CISPR 11		Group 1		The MT 200 uses RF energy only for its internal function. Therefore, its RF emissions are very low and are not likely to cause any interference in nearby electronic equipment.
RF emissions CISPR 11		Class B		The MT 200 is suitable for use in all establishments, including domestic establishments
Immunity test	IEC 60601 test level	Compliance level		Electromagnetic environment – guidance
Electrostatic discharge (ESD) IEC 61000-4-2	6 kV contact 8 kV air	6 kV contact 8 kV air		Floors should be wood, concrete or ceramic tile. If floors are covered with synthetic material, the relative humidity should be at least 30 %.
Power frequency (50/60 Hz) magnetic field  IEC 61000-4-8	3 A/m	3 A/m		Power frequency magnetic fields should be at levels characteristic of a typical location in a typical commercial or hospital environment.
Radiated RF IEC 61000-4-3	3 V/m 80 MHz to 2,5 GHz	3 V/m		$d = 1,2 \sqrt{P}$ 80 MHz to 800 MHz $d = 2,3 \sqrt{P}$ 800 MHz to 2,5 GHz Where P is the maximum output power rating of the transmitter in watts (W) according to the transmitter manufacturer and d is the recommended separation distance in meters (m). Field strengths from fixed RF transmitters, as determined by an electromagnetic site survey, a) should be less than the compliance level in each frequency range. B) Interference may occur in the vicinity of equipment marked with the following symbol: 

### Recommended separation distances between portable and mobile RF communications equipment and the MT 200

The MT 200 is intended for use in an electromagnetic environment in which radiated RF disturbances are controlled. The customer or the user of the MT 200 can help prevent electromagnetic interference by maintaining a minimum distance between portable and mobile RF communications equipment (transmitters) and the MT 200 as recommended below, according to the maximum output power of the communications equipment.

Rated maximum output power of transmitter W	Separation distance according to frequency of transmitter		
	m		
	150 kHz to 80 MHz $d = 1,2 \sqrt{P}$	80 MHz to 800 MHz $d = 1,2 \sqrt{P}$	800 MHz to 2,5 GHz $d = 2,3 \sqrt{P}$
0,01	0,12	0,12	0,23
0,1	0,38	0,38	0,73
1	1,2	1,2	2,3
10	3,8	3,8	7,3
100	12	12	23

For transmitters rated at a maximum output power not listed above, the recommended separation distance  $d$  in meters (m) can be estimated using the equation applicable to the frequency of the transmitter, where  $P$  is the maximum output power rating of the transmitter in watts (W) according to the transmitter manufacturer.

NOTE 1 At 80 MHz and 800 MHz, the separation distance for the higher frequency range applies.

NOTE 2 These guidelines may not apply in all situations. Electromagnetic propagation is affected by absorption and reflection from structures, objects and people.









Immunity test	IEC 60601 test level	Compliance level	Electromagnetic environment – guidance
<b>Electrical fast transient/burst</b> IEC 61000-4-4	+/-2 kV for power supply lines +/-1 kV for input/output lines	+/-2 kV for power supply lines +/-1 kV for input/output lines	Mains power quality should be that of a typical commercial or hospital environment.



**Note:**

- If the device is interfered by power or signal cable, image quality may be reduced or abnormally displayed. Such kind of interference images could be easily identified and differentiated from the physiological characteristics of patient and longer clinical time consumed but wouldn't have any diagnostic accuracy issue.
- If there is a certain frequency of image interference, there is a need of isolation or filtering of the RF signal.

**Description of Packaging Symbols**

Symbols	Illustration
	<p>Indicates that the package is heavy and two or more people are required to lift.</p>
	<p>The broken wine glass suggests that the product inside the packaging could be easily damaged if dropped or handled without care and attention. The contents are fragile!</p>
	<p>Package contains fragile electronic equipment. Care should be used when handling.</p>
	<p>Do not use forklift truck here.</p>
	<p>Do not use Spade truck here.</p>
	<p>Hand truck only.</p>
	<p>Do not use Razorback truck here.</p>
	<p>Indicates that an object is capable of being recycled - not that the object has been recycled or will be accepted in all recycling collection systems.</p>
	<p>Top. This side up.</p>

# ***Manufacturer's Limited Warranty***

Dyaco Canada Inc. warrants all its Spirit treadmill for a period of time listed below, from the date of retail sale, as determined by a sales receipt. Dyaco Canada Inc.'s responsibilities include providing new or remanufactured parts, at Dyaco Canada Inc.'s option, and technical support to our independent dealers and servicing organizations. In the absence of a dealer or service organization, these warranties will be administered by Dyaco Canada Inc. directly to a consumer. The warranty period applies to the following components:

## **Warranty**

Lifetime: Frame

10 Years: Motor

3 Years: Parts and Labour

**This warranty is not transferable and is extended only to the original owner.**

The warranty shall not apply to exercise units which are subject to misuse, neglect, accident or unauthorized repair and alterations.

This warranty provided herein is lieu of all other express warranties, any implied warranties, including any implied warranties of merchantability of fitness for particular purpose, are limited in duration to the first 36 months from date of purchase. All other obligations or liabilities, including liability for consequential damages are hereby excluded.

## ***REPAIR PARTS AND SERVICE***

All of the parts for the treadmill shown in figure can be ordered from Dyaco Canada Inc. 5955 DON MURIE STREET, NIAGARA FALLS, ONTARIO L2G 0A9. When ordering parts, the parts will be sent and billed at the current prices. Prices may be subject to change without notice. Check or money order must accompany all orders. Standard hardware items are available at your local hardware store.

To ensure prompt and correct handling of any errors, or to answer any questions, please call our Toll Free number: 1-888-707-1880, or local number 1-905-353-8955 or fax 1-905-353-8968 or email: [customerservice@dyaco.ca](mailto:customerservice@dyaco.ca). Office hours are from 8:30 AM to 5:00 PM Monday to Friday Eastern Standard Time.

Always include the following information when ordering parts

- \_ Model number
- \_ Name of each part
- \_ Part number of each part

# DYACO

CANADA INC.

Please visit us online for information about our other brands and products manufactured and distributed by Dyaco Canada Inc.



[www.dyaco.ca](http://www.dyaco.ca)



[www.dyaco.ca](http://www.dyaco.ca)



[www.dyaco.ca](http://www.dyaco.ca)



[www.dyaco.ca](http://www.dyaco.ca)



[www.spiritfitness.ca](http://www.spiritfitness.ca)  
[www.dyaco.ca](http://www.dyaco.ca)



[www.spiritmedical.ca](http://www.spiritmedical.ca)  
[www.dyaco.ca](http://www.dyaco.ca)



[www.solefitness.ca](http://www.solefitness.ca)  
[www.dyaco.ca](http://www.dyaco.ca)



[www.trainorsports.ca](http://www.trainorsports.ca)  
[www.dyaco.ca](http://www.dyaco.ca)



[www.xterrafitness.ca](http://www.xterrafitness.ca)  
[www.dyaco.ca](http://www.dyaco.ca)