

## Owner's Manual

**Model No.**  
16007606850-1

XT685

- Assembly
- Operation
- Adjustments
- Parts
- Warranty

**CAUTION:**  
Read and  
understand this  
manual before  
operating unit

# SPIRIT



**Retain For Future Reference**

# TABLE OF CONTENTS

Product Registration.....	3
Important Safety Instructions.....	4
Important Electrical Instructions.....	6
Assembly Instructions.....	8
Transportation Instructions.....	13
Operation of Your New Treadmill.....	14
Using the Spirit Fit App.....	18
Programmable Features.....	19
Target Heart Rate.....	27
Using a Heart Rate Transmitter .....	29
Heart Rate Control Operation.....	30
Parts List and Diagram .....	32
General Maintenance.....	35
Manufacturer's Limited Warranty .....	39

# ***SPIRIT***

**CONGRATULATIONS ON YOUR  
NEW TREADMILL**

Thank you for your purchase of this quality treadmill from Dyaco Canada Inc. Your new treadmill was manufactured by one of the leading fitness manufacturers in the world and is backed by one of the most comprehensive warranties available. Through your dealer, Dyaco Canada Inc. will do all we can to make your ownership experience as pleasant as possible for many years to come. The local dealership where you purchased this treadmill is your administrator for all warranty and service needs. Their responsibility is to provide you with the technical knowledge and service personnel to make your experience more informed and any difficulties easier to remedy.

Please take a moment at this time to record the name of the dealer, their telephone number, and the date of purchase below to make any future needed contact easy. We appreciate your support, and we will always remember that you are the reason that we are in business. Please go to [www.dyaco.ca/warranty.html](http://www.dyaco.ca/warranty.html) and complete the online warranty registration.

**Name of Dealer** \_\_\_\_\_  
**Telephone Number of Dealer** \_\_\_\_\_  
**Purchase Date** \_\_\_\_\_

## ***Product Registration***

### **RECORD YOUR SERIAL NUMBER**

Please record the Serial Number of this fitness product in the space provided below.

**Serial Number** \_\_\_\_\_

### **REGISTER YOUR PURCHASE**

Please visit us at [www.dyaco.ca/warranty.html](http://www.dyaco.ca/warranty.html) to register your purchase.

# IMPORTANT SAFETY INSTRUCTIONS

**THIS UNIT IS INTENDED FOR HOUSEHOLD USE ONLY  
READ ALL INSTRUCTIONS BEFORE USING THIS TREADMILL**

**CAUTION:** Before starting any exercise program, it is recommended that you consult your physician.

**WARNING:** Connect this unit to a properly grounded outlet only.

**DANGER:** To reduce the risk of electric shock, always unplug the treadmill from the electrical outlet immediately after using and before cleaning.

## WARNING

**TO REDUCE THE RISK OF BURNS, FIRE, ELECTRIC SHOCK, OR INJURY TO PERSONS:**

### Grounding Instructions

This product must be grounded. If it should malfunction or breakdown, grounding provides a path of least resistance for electric current to reduce the risk of electric shock. This product is equipped with a cord having an equipment-grounding conductor and a grounding plug. The plug must be plugged into an appropriate outlet that is properly installed and grounded in accordance with all local codes and ordinances. See the diagram below for grounding methods.

Figure 1.  
Grounding methods

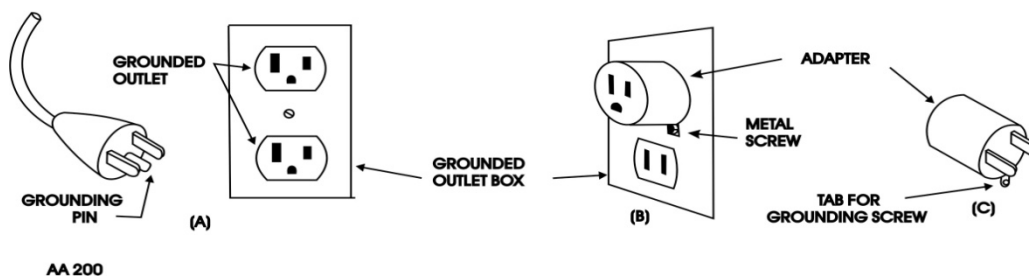

AA 200

1. Use 110 volt a.c. household current on a dedicated circuit.
2. It is the responsibility of the owner to ensure that all users of this treadmill are adequately informed of all warnings and precautions.
3. The use of an extension cord with this product is not recommended. If an extension cord is needed, use a short (less than 10 feet) heavy gauge (14 gauge or better) extension cord with a three prong (grounded) plug and receptacle.
4. Never leave the treadmill unattended when plugged in. Remove the safety key and unplug the unit from the outlet when not in use and before removing or replacing parts.
5. Never operate the treadmill if it has a damaged cord or plug if it is not working properly if it has been dropped, damaged, or exposed to water. Never move the treadmill belt while the power is turned off.
6. Do not pull the treadmill by the power supply cord or use cord as a handle. Keep cord away from heated surfaces and open flames.
7. Fitness equipment must always be installed and used on a flat surface. Do not use outdoors or near water. Do not place the unit on a loose rug or uneven surface. It is recommended to use an equipment mat to prevent the unit from moving while it is being used, which could possibly scratch or damage the surface of your floor. It is recommended to have a minimum of 3 meters of safe clearance on all sides of the treadmill while in use.

8. Keep the treadmill indoors, away from moisture and dust. Do not put the treadmill in a garage, covered patio or near water.
9. Do not operate the treadmill where aerosol products are used or where oxygen is being administered.
10. Read, understand and test the emergency stop procedure before using the treadmill.
11. Do not insert any objects into any openings.
12. Inspect and properly tighten all parts of the treadmill regularly.
13. Keep children and pets away from this equipment at all times while exercising.
14. Handicapped individuals should have medical approval and close supervision when using this treadmill.
15. Do not place hands or feet under the treadmill. Always keep hands and legs off of the treadmill when others are using it.
16. Never turn on treadmill while standing on tread-belt. Always hold the handrails while using the treadmill. Always return the treadmill to the slowest speed to provide for safe dismount and low speed restart.
17. To disconnect, turn all controls to the off position, then remove plug from outlet.
18. Do not attempt to raise, lower or move the treadmill until it is properly assembled. See page 13 on how to move the treadmill. Care must be taken when lifting or moving the equipment so as not to injure your back. Always use proper lifting techniques. You must not use any attachments that are not recommended by the manufacturer.
19. Use the treadmill only for its intended use as described in this manual. Do not use any attachments that are not recommended by the manufacturer.
20. User weight should not exceed 425 lbs (193 kgs).
21. Never allow more than one person on the treadmill at once.
22. Warm up 5 to 10 minutes before each workout and cool down 5 to 10 minutes afterward. This allows your heart rate to gradually increase and decrease and will help prevent straining muscles.
23. Never hold your breath while exercising. Breathing should remain at a normal rate in conjunction with the level of exercise being performed.
24. Start your program slowly and very gradually increase your speed and distance.
25. Always wear suitable clothing and footwear while exercising. Do not wear loose fitting clothing that could become entangled with the moving parts of your treadmill. Do not walk or jog barefoot, in stocking feet or loose fitting shoes or slippers.

**▲WARNING: Before beginning any exercise program, consult your physician. This is especially important for individuals over the age of 35 or persons with pre-existing health problems. Read all instructions before using any fitness equipment. We assume no responsibility for personal injury or property damage sustained by or through the use of this product.**

## SAVE THESE INSTRUCTIONS

# IMPORTANT ELECTRICAL INSTRUCTIONS

## **WARNING!**

**NEVER** remove any cover without first disconnecting AC power. If voltage varies by ten percent (10%) or more, the performance of your treadmill may be affected. Such conditions are not covered under your warranty. If you suspect the voltage is low, contact your local power company or a licensed electrician for proper testing.

**NEVER** expose this treadmill to rain or moisture. This product is NOT designed for use outdoors, near a pool or spa, or in any other high humidity environment. The temperature specification is 40 degrees C, and humidity is 95%, non-condensing (no water drops forming on surfaces).

**Circuit breakers:** Avoid AFCI/GFCI circuit breakers if possible. These breakers may occasionally trip during use because of the high inrush currents from the treadmill drive motor. This condition is an issue with all treadmills and other products with large motors or electric heating elements like ovens.

New laws in your area may require these breakers. If you do have these breakers and outlets in your home and are experiencing nuisance tripping, you should check to see if there are any other devices plugged into the same circuit like fluorescent lights with electronic ballasts, coffee makers, space heater, etc. Optimally the treadmill should be the only device plugged into the circuit.

Our treadmills have surge suppressors built in to help avoid nuisance tripping. We have tested several AFCI/GFCI breakers and outlets with our products that do not trip when only the treadmill is connected. Brands we have tested are Eaton (Cutler Hammer Series), Leviton (Smart lock pro) and Schneider Electric (Canadian home series).

This product must be grounded. If the treadmill should malfunction or breakdown, grounding provides a path of least resistance for electric current, reducing the risk of electric shock. This product is equipped with a cord having an equipment-grounding plug. The plug must be plugged into an appropriate outlet that is properly installed and grounded in accordance with all local codes and ordinances.

**DANGER - Improper connection of the equipment-grounding conductor can result in a risk of electric shock. Check with a qualified electrician or serviceman if you are in doubt as to whether the product is properly grounded. Do not modify the plug provided with the product if it will not fit the outlet, have a proper outlet installed by a qualified electrician.**

- **NEVER** operate this treadmill without reading and completely understanding the results of any operational change you request from the computer.
- Understand that changes in speed and incline do not occur immediately. Set your desired speed on the computer console and release the adjustment key. The computer will obey the command gradually.
- **NEVER** use your treadmill during an electrical storm. Surges may occur in your household power supply that could damage treadmill components.
- Use caution while participating in other activities while walking on your treadmill, such as watching television, reading, etc. These distractions may cause you to lose balance or stray from walking in the center of the belt, which may result in serious injury.
- **NEVER** mount or dismount the treadmill while the belt is moving. Spirit treadmills start at a very low speed, and it is unnecessary to straddle the belt during startup. Simply standing on the belt during slow acceleration is proper after you have learned to operate the unit.
- Always hold on to a handrail or hand bar while making control changes (incline, speed, etc.). Do not use excessive pressure on console control keys. They are precision set to function properly with little finger pressure. Pushing harder is not going to make the unit go faster or slower. If you feel the buttons are not functioning properly with normal pressure, contact your Spirit dealer.

# SAFETY TETHER CORD

A safety tether cord is provided with this unit. It is a simple magnetic design that should be used at all times. It is for your safety should you fall or move too far back on the tread-belt. Pulling this safety tether cord will stop tread-belt movement.

## To Use:

1. Place the magnet into position on the round metal portion of the console control head. Your treadmill will not start and operate without this. Removing the magnet also secures the treadmill from unauthorized use.

2. Fasten the plastic clip onto your clothing securely to assure good holding power.

**Note:** The magnet has strong enough power to minimize accidental, unexpected stopping. The clip should be attached securely to make certain it does not come off. Be familiar with its function and limitations. The treadmill will stop, depending on speed, with a one to two step coast anytime the magnet is pulled off the console. Use the red Stop/Pause switch in normal operation.

# ASSEMBLY INSTRUCTIONS

**!!ATTENTION: IMPORTANT UNPACKING INSTRUCTIONS.  
PLEASE READ BEFORE UNPACKING YOUR TREADMILL!!**

Cut the banding straps with a short box cutter (razor knife); separate the carton from the one underneath it by prying up on the staples (if applicable). Pull the carton over the treadmill parts and locate the hardware pack. The hardware pack is separated into five sections; one section containing tools and four sections labelled steps 1-4 which contain the hardware needed for assembly of each step. The assembly steps below are numbered one through four and correspond to the hardware in the numbered sections of the hardware pack. Remove only the hardware for the step you are currently assembling to avoid confusion and mix ups.

Then remove the treadmill from the carton and lay it on a level surface.

## ASSEMBLY TOOLS

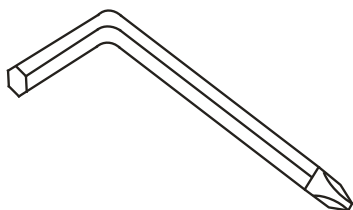

**#103.** Combination M5 Allen Wrench & Phillips Head Screwdriver

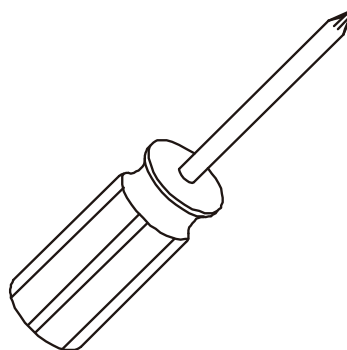

**#126.** Phillips Head Screwdriver

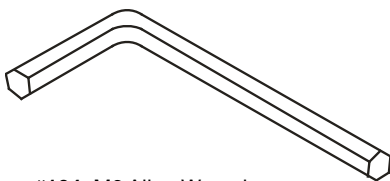

**#104.** M6 Allen Wrench



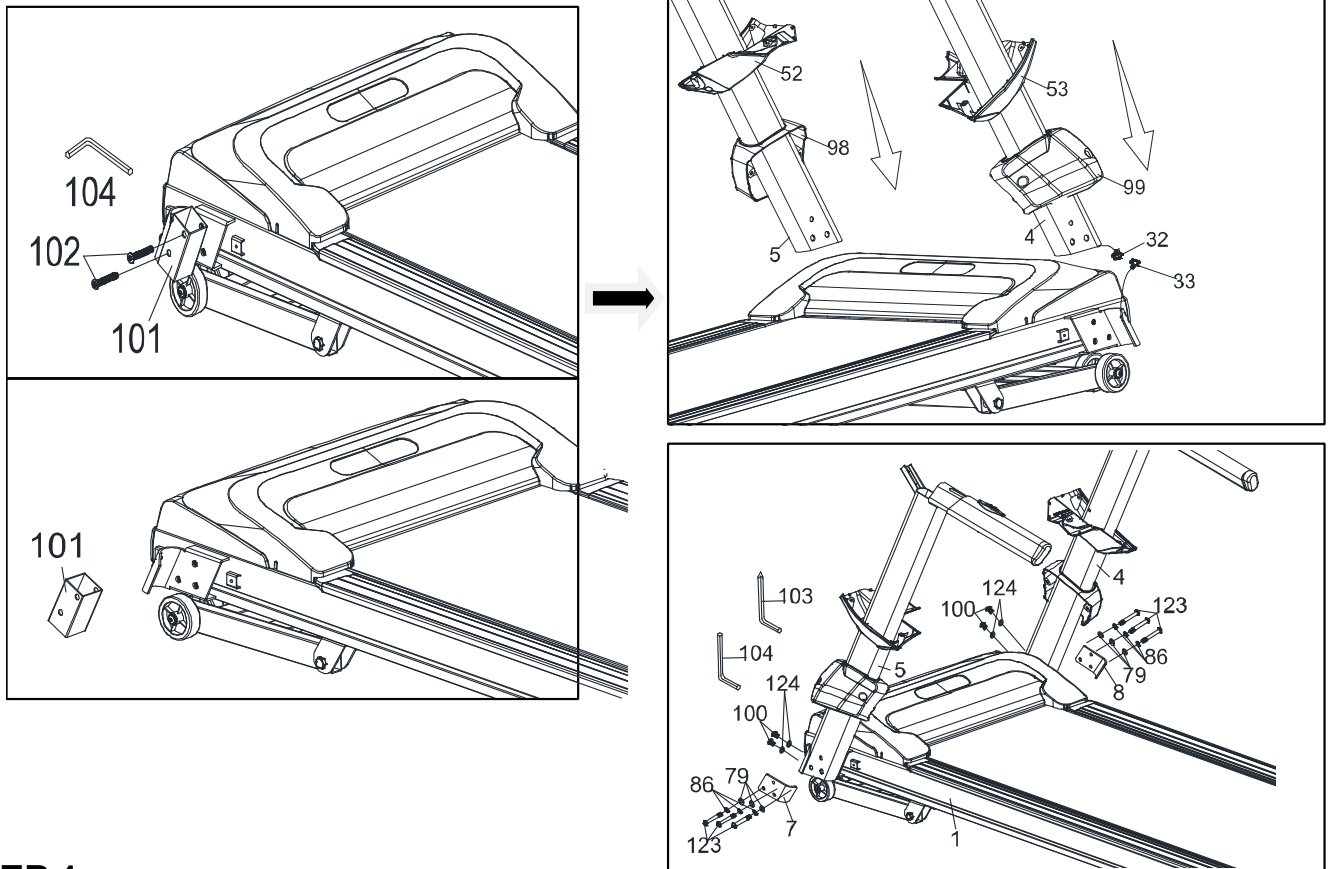

## STEP 1

1. Take out the treadmill from the carton and lay it aside on the smooth ground.
2. Remove(L/R) Flat Head Socket Bolts (102) using the L Allen Wrench (104) and then remove 2 pcs Fixing Plate Stabilizer (101) and dispose of.
3. Slide the **UPRIGHT COVERS (L 52, R 53)** onto the **LEFT AND RIGHT UPRIGHTS (4, 5)**.
4. Slide the **CONSOLE MAST SIDE CAPS (L 98, R99)** onto the **LEFT AND RIGHT UPRIGHTS (4, 5)** under the Upright Covers.
5. Connect the **LOWER COMPUTER CABLE (33)** to the **MIDDLE COMPUTER CABLE (32)**. Be sure not to pinch the cable, or damage may occur.
6. Insert the **LEFT AND RIGHT UPRIGHTS** into the **MAIN FRAME (1)** and use the **COMBINATION WRENCH AND PHILLIPS SCREWDRIVER (103)** to secure 4 **BOLTS (100)** and 4 **Curved Washers (124)** into place.
7. Use the **L-SHAPED ALLEN WRENCH (104)** to tighten the **LEFT AND RIGHT GUSSET (7, 8)** with 6 **Bolts (123)**, 6 **FLAT WASHERS (79)**, and 6 **SPRING WASHERS (86)**.

## HARDWARE

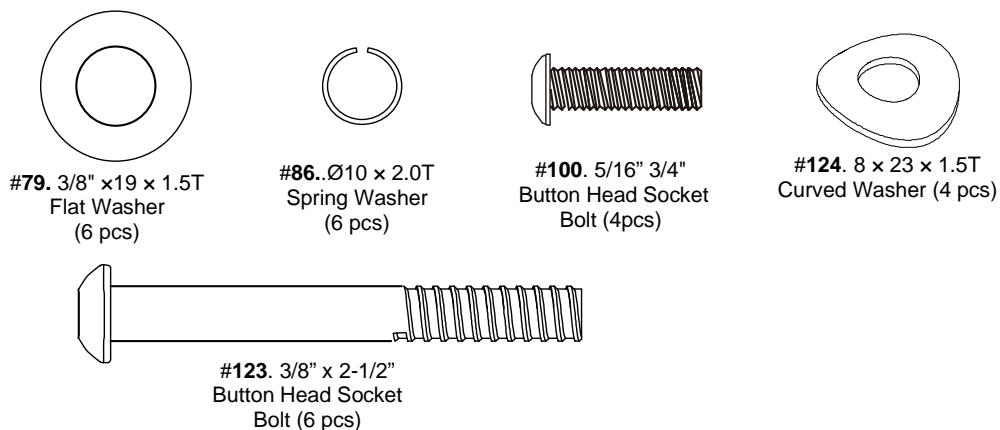

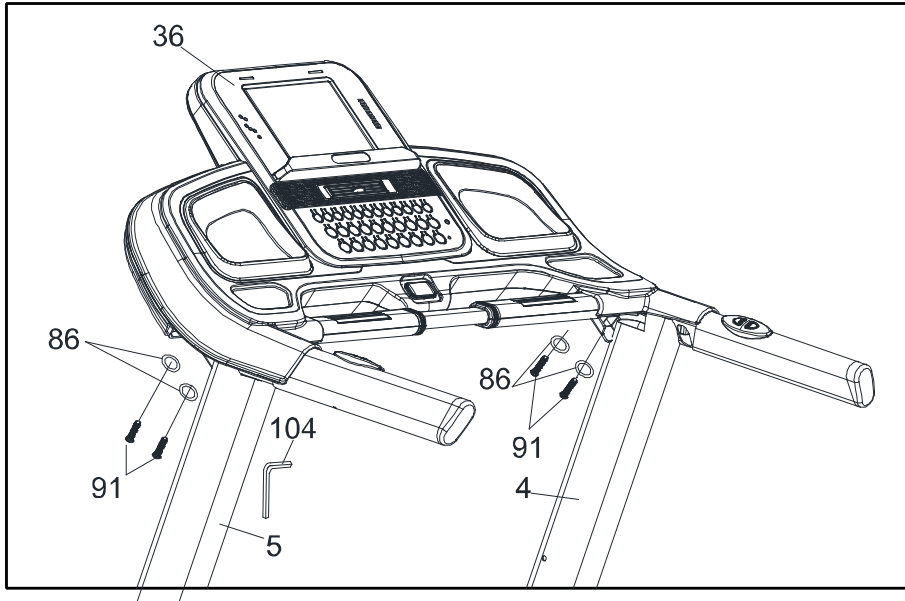
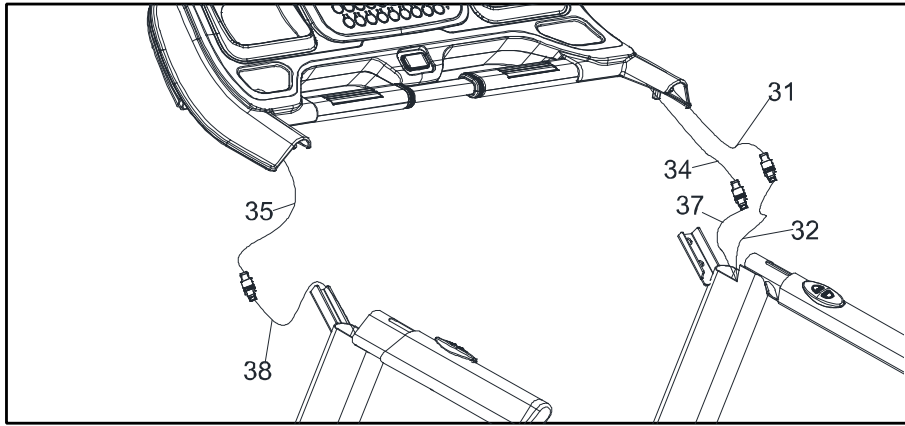

## STEP 2

1. Connect the **SPEED ADJUSTMENT SWITCH W/ CABLE (37)** with the **UPPER SPEED CABLE (34)**.
2. Connect the **INCLINE ADJUSTMENT SWITCH W/ CABLE (38)** with the **UPPER INCLINE CABLE (35)**.
3. Connect the **MIDDLE COMPUTER CABLE (32)** to the **UPPER COMPUTER CABLE (31)**.
4. Be sure not to pinch any of the cables, or damage may occur to the system.
5. Insert the **CONSOLE ASSEMBLY (36)** onto the **RIGHT AND LEFT UPRIGHTS (4, 5)** and secure with 4 **BUTTON HEAD SOCKET BOLTS (91)** and 4 **SPRING WASHERS (86)**. Use the **ALLEN WRENCH (104)** to tighten.

## HARDWARE

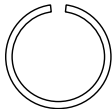

#86. Ø10 x 2.0T  
Spring Washer (4 pcs)



#91. 3/8" x 1-3/4"  
Button Head Socket  
Bolt (4 pcs)

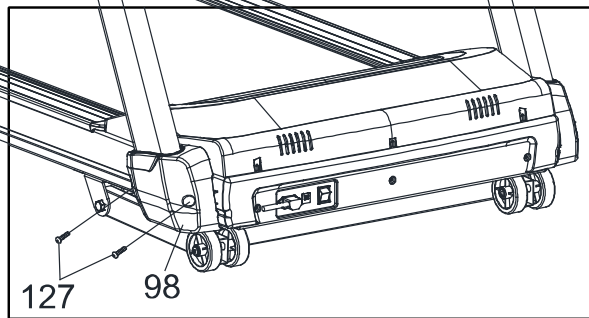
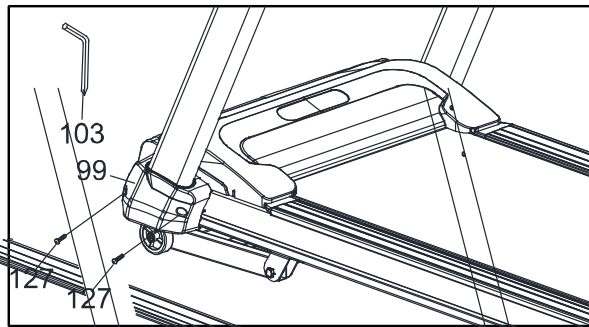
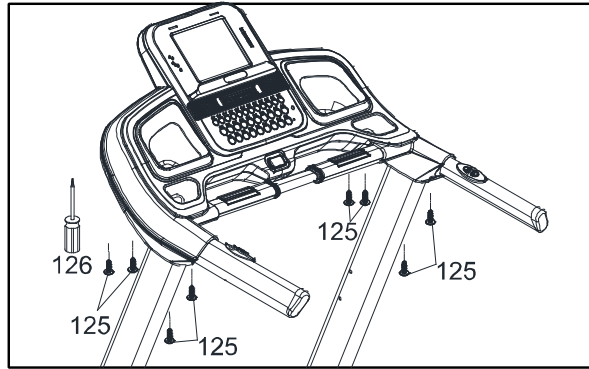
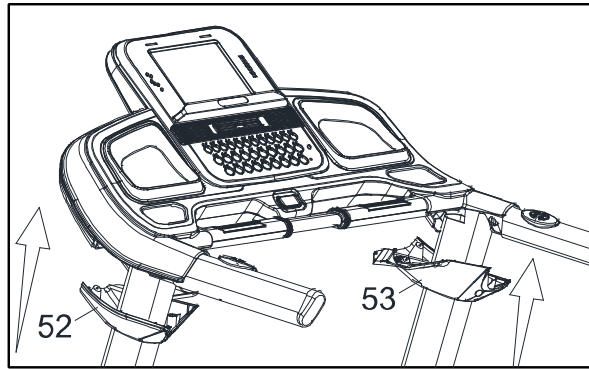

### STEP 3

1. Slide **UPRIGHT COVERS RIGHT AND LEFT (53, 52)** up the uprights. Secure them with **8 SHEET METAL SCREWS (125)** using the **PHILLIPS HEAD SCREWDRIVER (126)**.
2. Install the **CONSOLE MAST SIDE CAP (L 98, R 99)** onto the **MAIN FRAME (1)** and secure it using **4 PHILLIPS HEAD SCREWS (127)** by using the **COMBINATION WRENCH AND PHILLIPS SCREWDRIVER (103)**.

### HARDWARE

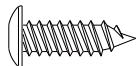

#125. 3.5 x 16mm  
Sheet Metal Screw  
(8 pcs)



#127. M5 x 10mm  
Phillips Head Screw  
(4 pcs)

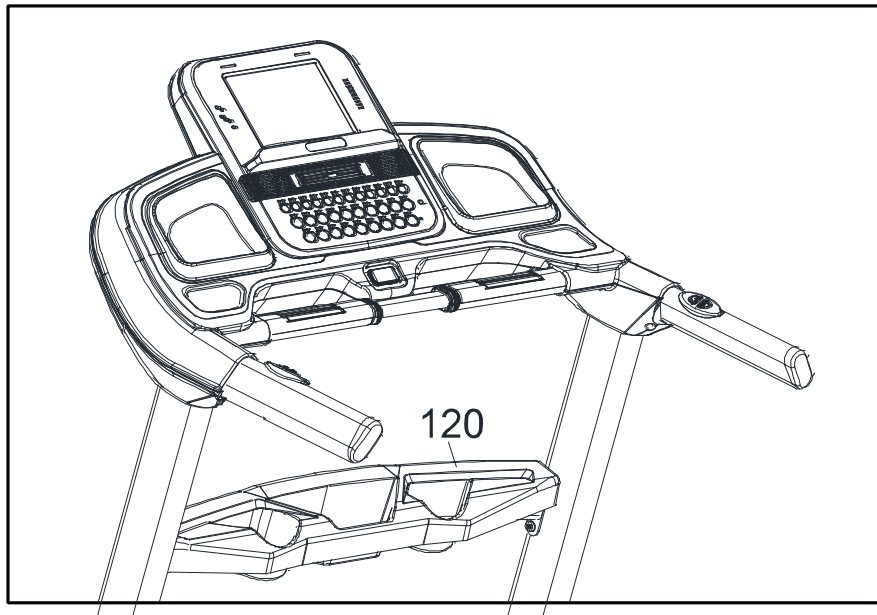
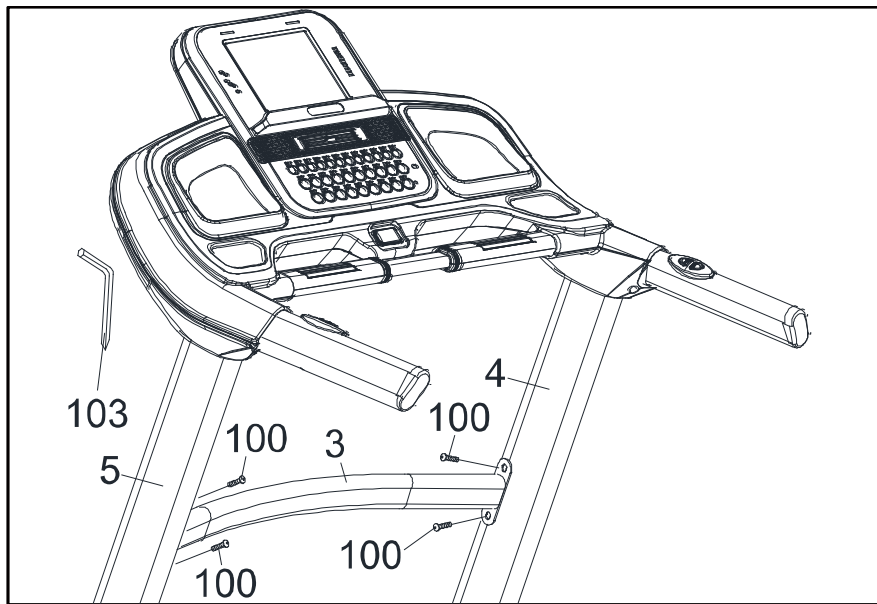

## STEP 4

1. Place the **HANDRAIL SUPPORT (3)** between the **LEFT AND RIGHT UPRIGHTS (5, 4)** and use the **COMBINATION ALLEN WRENCH & PHILLIPS HEAD SCREWDRIVER (103)** to tighten 4 **BUTTON HEAD SOCKET BOLTS (100)**.
2. Place the **BEVERAGE HOLDER (120)** onto the **HANDRAIL SUPPORT (3)**.

## HARDWARE



#100. 5/16" x 3/4"  
Button Head Socket  
Bolt (4 pcs)

# TRANSPORTATION INSTRUCTIONS

Before moving the treadmill, turn the power switch off located in front of the motor cover and unplug the power cord.

**Caution:** You must be able to safely lift 20 kg (45lbs) in order to raise\lower and move the treadmill.

**To protect the floor or carpet from damage, place a mat under the treadmill. Keep the treadmill out of direct sunlight.**

To reduce the risk of injury, use extreme caution while moving the treadmill, do not attempt to move the treadmill over an uneven surface.

Carefully lift the treadmill at the rear roller area, grasping the two end caps, and roll the treadmill away.

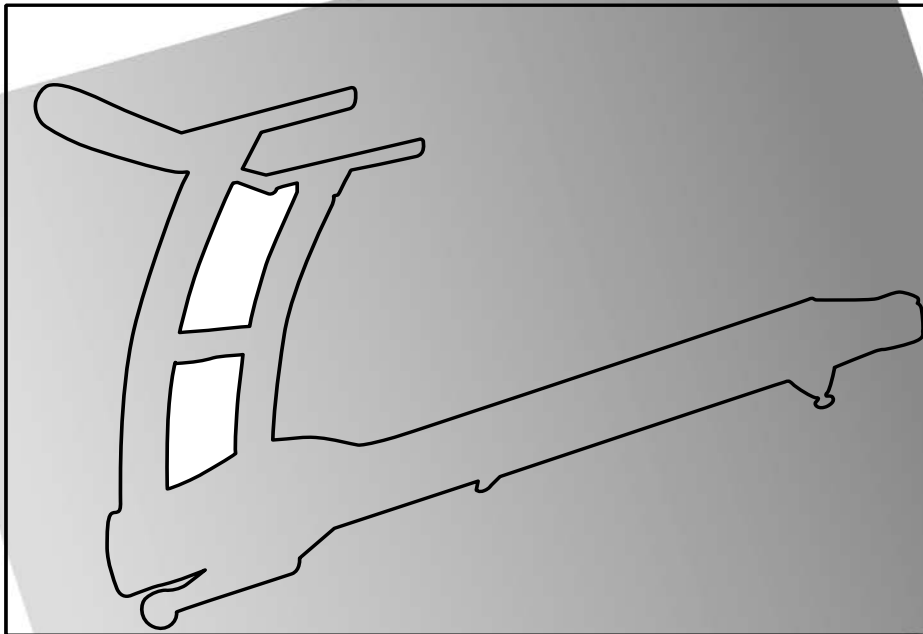

# OPERATION OF YOUR TREADMILL

## GETTING FAMILIAR WITH THE CONTROL PANEL

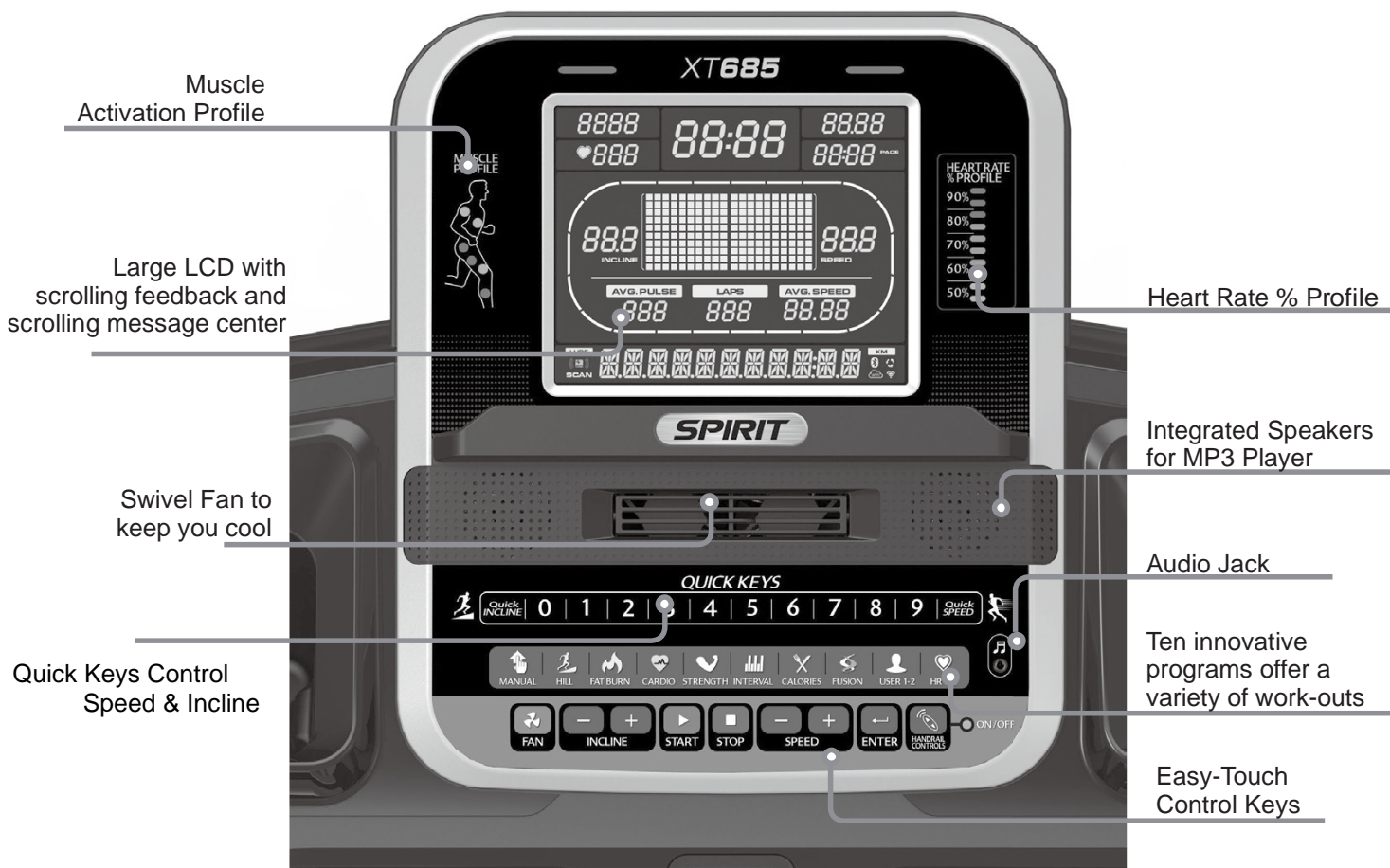

## FEATURES

### HANDRAIL ADJUSTMENTS

The treadmill allows you to make speed and incline changes on the side handrails. You can also choose to turn these off if you frequently hold on to these rails. This is achieved by pressing the disable button on the right side of the lower portion of the console.

### QUICK SPEED AND INCLINE BUTTONS

You are able to set your speed and incline settings quickly by using the quick keys on the console. Just press either Speed or Incline, then select either 2 or 3 digits, and the treadmill will automatically adjust to that value. This saves time because you don't have to press and hold or hold a button down until reaching the desired value. The maximum value you may input for speed is 12.0 MPH (18.0 KPH) and incline 15.0%

**Examples:** Press the **Quick Incline** button, then 1, 0 = Incline Level 1.0

Press the **Quick Incline** button, then 3, 5 = Incline Level 3.5

Press the **Quick Speed** button, then 8, 0 = 8.0 MPH or KPH

Press the **Quick Speed** button, then 0, 8 = 0.8 MPH or KPH

## **CONSOLE**

### **MUSCLE ACTIVATION FIGURE**

There is an anatomical figure located at the top of the console. This figure will light all areas that are activated when using the treadmill. These will light up during any of the programs. You can control which muscles are activated by changing the incline and swinging your arms. The preset programs will determine which lower body muscles will be activated by automatically adjusting the incline. Generally, the following guidelines hold true:

- The upper body LED's will light any time your hands aren't in contact with the pulse grip sensors
- The lower body lights will activate in three degrees of engagement: Green represents minimal muscle involvement, Amber represents medium involvement, and Red represents full or heavy activation.
- 0-4.5% Elevation: even muscle distribution, all four muscle groups will be Amber
- 5-15% Elevation: Quads are Amber and Glutes, Hamstrings, and Calves are Red

### **MESSAGE CENTER**

The console will display Pace; Calories burned, Time (elapsed or countdown), Distance travelled, Pulse, Speed, Incline, Program Name, # of Laps completed, and Segment Time. There is also a Speed & Incline profile graph that lets you see how hard you have worked and how challenging the upcoming segments will be.

### **HEART RATE % PROFILE**

The console LCD screen will display your current heart rate anytime a pulse is detected. The Bar Graph, located to the right of the LCD screen, will show your current heart rate % in relation to your projected maximum heart rate, which is determined by your age that you entered during the programming phase of any of the 12 programs. The significance of the bar graph colours are as follows:

- 50-60% of maximum is Amber
- 65-80% of maximum is Amber and Green
- 85-90% or more is Amber, Green, and Red

### **DOT MATRIX CENTER DISPLAY**

Twenty columns of boxes (10 high) indicate each segment of a workout. The boxes only show an approximate level (resistance) of effort. They do not necessarily indicate a specific value - only an approximate percent to compare levels of intensity. In Manual Operation, the resistance dot matrix window will build a profile "picture" as values are changed during a workout. The speed and incline profiles will display half of the program at one time (10 columns). They will both scroll right to left.

### **1/4 MILE TRACK**

The 1/4-mile track (one lap) will be displayed around the dot matrix window. The flashing segment indicates your progress. Once the 1/4-mile (Metric - 0.4km) is complete, this feature will begin again. The Lap track will move in a counterclockwise direction. There is a lap counter in the message window for monitoring your distance.

### **PULSE GRIP FEATURE**

The Pulse (Heart Rate) window will display your current heart rate in beats per minute during the workout. You must use both stainless steel sensors on the stationary grips or the heart rate transmitter chest strap to display your pulse. Pulse value displays anytime the upper display is receiving a Pulse signal. You may not use the Pulse Grip feature while in Heart Rate Programs.

## CALORIE DISPLAY

Displays the cumulative calories burned at any given time during your workout.

**Note:** This is only a rough guide used for comparison of different exercise sessions and is not to be used for medical purposes.

## SPEAKERS

The console has built-in speakers and an audio input jack. There is no volume control on the console. The volume must be controlled on the Audio Source.

## QUICKSTART

1. Press and release the **Start** key to wake display up (if not already on).  
**Note:** Installing the tether key will also wake up the console.
2. Press and release the **Start** key to begin belt movement at .5MPH, then adjust to the desired speed using the **Speed + / – or Fast/Slow keys** (console or hand rail). You may also use the **quick speed key**, then 0 through 9, to adjust the speed.
3. To slow the tread-belt, press and hold the “–” key (console or hand rail) to the desired speed. You may also press the quick speed adjust keys, 0 through 9.
4. To adjust the Incline level, pressed and hold the **Incline + / – or Up/Down keys**; you may also adjust to the desired incline by pressing the **Quick Incline key** and then 0 through 9.
5. To stop the tread-belt, press and release the **Stop** key.

## PAUSE/STOP/RESET/FEATURE

1. When the treadmill is running, the pause feature may be utilized by pressing the **Stop** key once. This will slowly decelerate the tread-belt to a stop. The incline will go to zero percent. The Time, Distance and Calorie readings will hold while the unit is in the pause mode. After 5 minutes, the display will reset and return to the start up screen.
2. To resume your exercise, when in Pause mode, press the **Start** key. The speed and incline will return to their previous settings.
  - Pause is executed when the **Stop** button is pressed once. If the **Stop** key is pressed a second time, the program will end, and a workout summary will be displayed. If the **Stop** button is pressed a third time, the console will return to the idle mode (start up) screen. If the **Stop** button is held down for more than 3 seconds, the console will reset.

## INCLINE FEATURE

- Incline may be adjusted anytime after belt movement.
- Press and hold the **Incline + / – or Up/Down keys** (console or hand rail) to achieve desired level of effort. You may also choose a more rapid increase/decrease by selecting the **Quick Incline key**, then 0 through 9.
- The display will indicate incline percent in increments of .5 as adjustments are made.
- The incline will return to zero unless the main power switch or safety key are turned off while incline is at a higher setting.

## HANDRAIL BUTTONS DISABLE SWITCH

To the right of the Enter button, there is a Handrail control switch and an indicator light next to it. When the indicator light is lit, the handrail switches are disabled. This allows you to use the full length of the handrails without fear of activating the speed or elevation controls.



## TO TURN TREADMILL OFF

1. Display will automatically turn off (go to sleep) after 30 minutes (no key operations). The treadmill will draw very little current in display mode (about as much as your television when it is turned off).
2. Remove the tether cord.
3. Turn off the main switch on the front of the treadmill below the motor cover.

## PROGRAM KEYS

The program keys are used to preview each program. When you first turn the console on, you may press each program key to preview what the program profile looks like. If you decide that you want to try a program, press the corresponding program key and then press the **Enter** key to select the program and enter into the data-setting mode.

The treadmill has a built in heart rate monitoring system. Simply grasping the hand pulse sensors on the stationary handle bars or wearing the heart rate transmitter (see Using Heart Rate Transmitter section) will start the Heart Icon blinking (this may take a few seconds). The Pulse Display Window will display your heart rate or Pulse in beats per minute.

The console includes a built-in fan to help keep you cool. To turn the fan on, press the key on the left side of the console.

## PROGRAMMING THE CONSOLE

Each of the programs can be customized with your personal information and changed to suit your needs. Some of the information is necessary to ensure the readouts are correct. You will be asked for your Age and Weight. Entering your Age is necessary during the Heart Rate programs to ensure the correct predicted target heart rate zone. Entering your Weight aides in calculating a correct Calorie reading. Although we cannot provide an exact calorie count, we do want to be as close as possible.

**CALORIE NOTE:** Calorie readings on every piece of exercise equipment, whether it is in a gym or at home, are only an estimate and tend to vary widely. They are meant only as a guide to monitor your progress from workout to workout.

## ENTERING A PROGRAM AND CHANGING SETTINGS

When you enter a program, by pressing a program key, then **Enter** key, you have the option of entering your own personal settings. If you want to work out without entering new settings, then just press the **Start** key. This will bypass the programming of data and take you directly to the start of your workout. If you want to change the personal settings, then just follow the instructions in the Message Center. If you start a program without changing the settings, the default or saved settings will be used.

**NOTE:** Age and Weight default settings will change when you enter a new number. So the last Age and Weight entered will be saved as the new default settings. If you enter your Age and Weight the first time you use the treadmill, you will not have to enter it every time you work out unless either your Age or Weight changes, or someone else enters a different Age and Weight. Each preset program has a maximum Speed and Incline level that is displayed when a desired workout is chosen. The maximum Speed and Incline that the particular program will achieve will be displayed in the Message Center.

# USING THE SPIRIT FIT APP

In order to help you achieve your exercise goals, your new exercise machine comes equipped with a Bluetooth® transceiver that will allow it to interact with selected phones or tablet computers via the Spirit Fit App.

Just download the free Spirit Fit App from the Apple Store or Google Play, and then follow the instructions in the App to sync with your exercise machine. Now you can view current workout data on three different Display screens on your device. You can also easily switch back and forth from the workout display view to internet/social media/email sites via icons on the display screen. When your workout is finished, the data is automatically saved to the built-in personal calendar for future reference.

The Spirit Fit App also allows you to sync your workout data with one of many fitness cloud sites we support: iHealth, MapMyFitness, Record or Fitbit, with more to come.

Syncing the App with your exercise machine:

1. Download the App.
2. Open the App on your device (phone or tablet) and make sure Bluetooth® is enabled on your device (phone or tablet).
3. In the App, click the icon in the top left corner to search for your Spirit equipment (shown right).

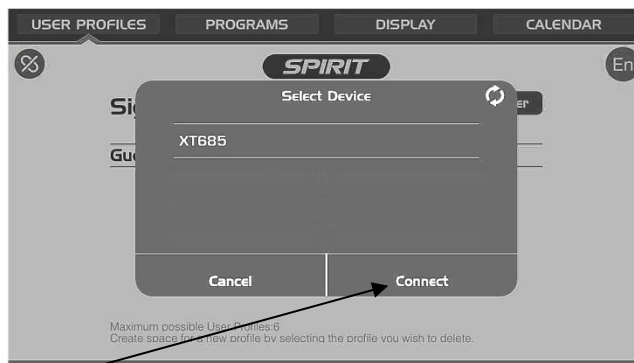
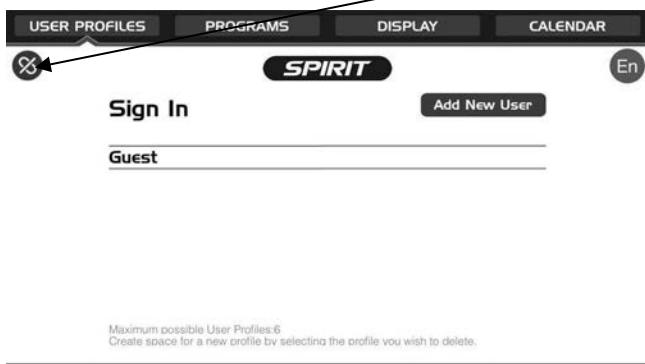

4. After the equipment is detected, click Connect. When the App and equipment are synced, the Bluetooth® icon on the equipment's console display will light up. You may now start using your new Spirit Fitness product.
5. When your workout is finished, the data is automatically saved, and you will be prompted to sync your data with each available fitness cloud site. Please note you will have to download the applicable compatible fitness App, such as iHealth, MapMyFitness, Record, Fitbit, etc., in order for the icon to be active and available.

**\*Note: Your device will need to be running on a minimum operating system of iOS 7 or Android 4.4 for the Spirit Fit App to operate properly.**

# PROGRAMMABLE FEATURES

## SELECTING A PROGRAM

The treadmill offers nine factory preset programs, two user defined programs and one Manual program. Each preset program has a maximum speed level that is displayed when a desired workout is chosen. The maximum speed that the particular program will achieve will be displayed in the Speed window.

Also included are two user programs (**User 1** and **User 2**) for custom workouts.

1. Press the desired **Program (Hill, Fat burn, Cardio, Strength Interval, Calories, and Fusion)** key. Press **Enter** to select the program. The display will prompt you through the programming, or you can just press **Start** to begin the program with default values.
2. If **Enter** was pressed, the **Message center** will now be blinking a value, indicating your **Age** (default is 35). Entering your correct age affects the heart rate Bar Graph Display and the Heart Rate programs. Use the **+ or – keys** to adjust, then press **Enter**. Your age determines your recommended maximum heart rate. Since the Bar Graph Display and the Heart Rate features are based on a percentage of your maximum heart rate, it is important to enter the correct age for these features to work properly.
3. The Message center will now be blinking a value, indicating your **Body Weight** (default is 150 lbs/70kgs.). Entering the correct bodyweight will affect the calorie count. Use the **+ or – keys** to adjust, then press **Enter**.  
*A note about the Calorie display: No exercise machine can give you an exact calorie count because there are too many factors that determine exact calorie burn for a particular person. Even if someone is the exact same bodyweight, age and height, their calorie burn may be very different than yours. The Calorie display is to be used as a reference only to monitor improvement from workout to workout.*
4. The Message Center will be blinking a value, indicating **Time** (the default value is 30 minutes). You may use any of the + or - keys to adjust the time. After adjusting, or to accept the default, press **Enter**.  
(*Note: You may press start at any time during the programming to start the program*).
5. The Message Center will now be blinking the preset top speed of the selected program (3 MPH or 5 KPH). Use the **Speed + or – keys** to adjust, then press **Enter**. Each program has various speed changes throughout; this allows you to limit the highest speed the program can reach.
6. The Message Center will be blinking the preset top incline of the selected program. Use the **Incline + / - keys** to adjust, then press **Enter**. You are now done programming data and may press **Start** to begin your workout or **Stop** to go back one level to change data entered in the programming phase.

## CUSTOM USER DEFINED PROGRAMS

1. Press the **User 1-2 key** once for **User 1** or twice for **User 2**, then press **Enter**. Note that the dot matrix display portion will have a single row of segments at the bottom (Unless there is a previously stored program).
2. If there is a program stored under the button that is pressed, it will be retrieved. If not, you have the option of programming in your first name. The message window will display and flash the letter "A." To change it, press the **Speed +** key, then "B" will be displayed; if the

**Speed** - key is pressed, the letter “Z” will be displayed. After selecting the appropriate letter, press enter. The letter “A” will again be displayed and blinking. Repeat the procedure until all letters of your first name are programmed (7 characters maximum). When your name is displayed, press **Stop** and it will be stored under either **User 1** or **User 2**.

3. The Message Center will now be blinking an Age value. Use the **Incline +/- keys** or **Speed +/- keys** to adjust. Press **Enter**. This is a must to continue even if age is not adjusted.
4. The Message Center will now be blinking a bodyweight value. Enter your bodyweight and press **Enter**.
5. Note the clock/Message Center is flashing. Use the **+ / -** keys to adjust up from 30 minutes (if desired). Press the **Enter** key. This is a must to continue even if time is not adjusted.
6. The first column (segment) will now be blinking. Using the **Speed +/- keys** or **Quick keys**, adjust the speed level to your desired effort for the first segment, then press **Enter**. The second column will now be blinking. Repeat the above process until all segments have been programmed. The first column will be blinking again. This is for the incline programming. Repeat the above process to program all segments for incline.

**Note: While in a User program, if you change the speed, all segment speeds from there on will also change.**

**Examples:** If you increase your current speed by 1 MPH (1.6 KPH), the remaining segment speeds will increase by 1 MPH (1.6 KPH). If you decrease your current speed by .5 MPH (0.8 KPH), the remaining segment speeds will decrease by .5 MPH (0.8 KPH), etc.

7. Press the **Start** button to begin the workout and also save the program to memory.
8. The profile picture will be re-scaled to fit in the window, but the actual speed and incline settings will remain the same as programmed.

## CALORIE PROGRAM

1. Press the **Calorie** key to select this program. The display will prompt you through the programming.
2. The Message Center will now be blinking a value, indicating your Age (default is 35). Entering your correct age affects the heart rate Bar Graph Display and the Heart Rate programs. Use the **+ or - keys** to adjust, then press **Enter**. Your age determines your recommended maximum heart rate. Since the Bar Graph Display and the Heart Rate features are based on a percentage of your maximum heart rate, it is important to enter the correct age for these features to work properly.
3. The Message Center will now be blinking a value, indicating your Body Weight (default is 150). Entering the correct bodyweight will affect the calorie count. Use the **+ or - keys** to adjust, then press **Enter**.

**A note about the Calorie display:** No exercise machine can give you an exact calorie count because there are too many factors that determine exact calorie burn for a particular person. Even if someone is the exact same bodyweight, age and height, their calorie burn may be very different than yours. The Calorie display is to be used as a reference only to monitor improvement from workout to workout.

4. The Message Center displays “Use the **speed + or – keys** to adjust Calorie burn” (default is 300); after adjusting, press **Enter**.
5. The Message Center will now be blinking the preset top speed of the selected program (3 MPH or 5 KPH). Use the **+ or - keys** to adjust, then press **Enter**. Each program has various speed changes throughout; this allows you to limit the highest speed the program can reach.
6. The Message Center will be blinking the preset top incline of the selected program (1.0%). Use the **speed + or – keys** to adjust, then press **Enter**.

7. The Message Center displays the Program Time (a value that that was determined by the data you entered in steps 2-6); Press **Start** to accept the calculated Time or **Enter** to return to steps 3-6 and change the data, which will recalculate the Program Time.
  - When the **Start** key is pressed, the program begins with a 3:00 warm up (1:00 @ 1MPH/KPH, 1:00 @ 2MPH/KPH, and 1:00 @ 3MPH/KPH), or you have the option of pressing the **Start** again to bypass and begin the workout.
  - When the program begins, both the Calorie and Time windows will count down to 0. If the Time expires before calories burned reaches 0, the Time window will begin accumulated time, until Calories reach 0.
  - After the program has ended, there will be a 3:00 cool down (1:00 @ 3MPH/KPH, 1:00 @ 2MPH/KPH, and 1:00 @ 1MPH/KPH) or you have the option of pressing the **Stop** key to end the workout.

## FUSION PROGRAM

1. Press the **Fusion** key. The display will prompt you through the programming.
2. The Message Center will now be blinking a value, indicating your Age (default is 35). Entering your correct age affects the heart rate Bar Graph Display and the Heart Rate programs. Use the **speed + or - keys** to adjust, then press **Enter**. Your age determines your recommended maximum heart rate. Since the Bar Graph Display and the Heart Rate features are based on a percentage of your maximum heart rate, it is important to enter the correct age for these features to work properly.
3. The Message Center will now be blinking a value, indicating your Body Weight (default is 150). Entering the correct bodyweight will affect the calorie count. Use the **+ or - keys** to adjust, then press **Enter**.

**A note about the Calorie display:** No exercise machine can give you an exact calorie count because there are too many factors that determine exact calorie burn for a particular person. Even if someone is the exact same bodyweight, age and height, their calorie burn may be very different than yours. The Calorie display is to be used as a reference only to monitor improvement from workout to workout. The calorie count displayed in this program won't be accurate because the machine can't calculate calories expended while strength training
4. The Message Center will now be blinking the preset top speed of the selected program (3 MPH or 5 KPH). Use the **speed + or - keys** to adjust, then press **Enter**. Each program has various speed changes throughout; this allows you to limit the highest speed the program can reach.
5. The Message Center will be blinking the preset top incline of the selected program (1.0%). Use the **speed + or - keys** to adjust, then press **Enter**.
6. The Message Center will be blinking the # of intervals desired (default is 10; you may select 10, 20, or 30). Use the **speed + or - keys** to adjust, then press **Enter**.
7. The Message Center will be blinking the desired Interval time (default is 1:00). The time you select will be the duration of both the cardio & strength intervals.

**Note:** on average, you will complete 15-20 repetitions of the strength exercise in a 0:30 interval. As a general rule, the longer the interval, the less weight (dumbbells) and speed (treadmill) required; use the **+ or - keys** to adjust, then press **Enter**.
8. The Message Center will be blinking the desired recovery time. The default setting is 0:30 you desire after completing both the cardio & strength intervals. Use the **+ or - keys** to adjust, then press **Enter**

## **PROGRAM EXAMPLE**

- The user selects 10 intervals (5 cardio and 5 strength) with the following interval durations – length of each cardio & strength interval is 0:30, recovery interval is 1:00
- Program begins with a 3:00 warm up (1:00 @ 1MPH/KPH, 1:00 @ 2MPH/KPH, and 1:00 @ 3MPH/KPH)
- 1st cardio interval begins, lasting 0:30; console counts down to 0:00, and the Message Center displays “STRENGTH INTERVAL 1 BEGIN DUMBBELL ROW.”
- User steps off of the treadmill to perform the strength exercise. The console counts down to 0:00 and beeps 3x, signalling the user to get back on the treadmill.
- Console displays “PRESS START TO BEGIN RECOVERY”; user walks @ 2MPH/KPH for 1:00
- Console then displays 2nd cardio interval, and the process proceeds until the user has performed 5 cardio, strength, and recovery intervals; the 5 strength exercises will be performed sequentially as listed in this manual.
- The last 2:00 are a Cool Down phase with the user walking on the treadmill @ 2 MPH/KPH
- If 20 intervals was selected, you would perform each strength exercise twice before moving on to the next exercise. If 30 intervals is selected, you will perform each exercise once, then repeat the sequence of all 5 exercises a 2nd & 3rd time.

### **CAUTION:**

Exercises that require dumbbell use - Select a pair of dumbbells that you will be able to safely and effectively maneuver over the strength interval time you have chosen.

# DUMBBELL BENT OVER ROW

EMPHASIS: MID/UPPER BACK & FRONT OF ARMS

1. Grasp the dumbbells with an overhand grip and arms fully extended in front of thighs; feet are spaced shoulder width apart
2. Maintain a slightly arched lower back throughout the exercise (see side view)
3. Begin the exercise by drawing your elbows up and out until there is a 90° bend in your elbows
4. Slowly lower the dumbbells back to the start position
5. Repeat this sequence for the duration of the strength interval



# PUSH UP

EMPHASIS: CHEST, SHOULDERS, & BACK OF ARMS

There are two variations of this exercise. If you aren't able to perform the exercise as shown in this illustration, place your knees on the floor, a padded mat, or a pillow. Also, a wider hand position places more eMPHasis on the chest and shoulder muscles, while a narrower hand position places more eMPHasis on the Tricep muscles (back of the arm)

1. Place your hands on the floor or a set of dumbbells (Caution: be aware that the dumbbells may roll and result in injury, especially if the ends are round); draw your stomach muscles towards your spine to maintain a straight line between your ankles and shoulders
2. Begin with your elbows bent at 90°
3. Fully straighten your arms
4. Repeat this sequence for the duration of the strength interval.

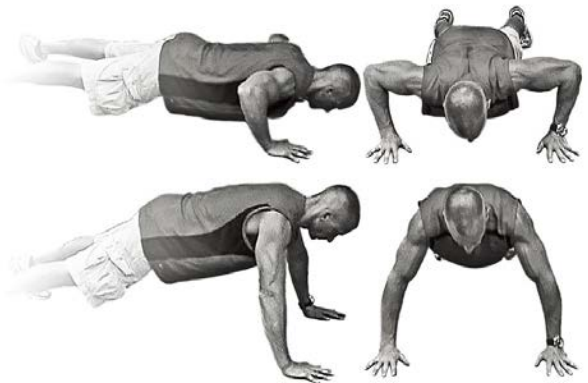

## DUMBBELL SHOULDER PRESS

EMPHASIS: SHOULDERS

1. Hold the dumbbells at shoulder height with an overhand (palms facing forward) or neutral (palms facing one another) grip
2. Press the dumbbells straight overhead until your arms are fully extended
3. Slowly lower to the start position
4. Repeat this sequence for the duration of the strength interval

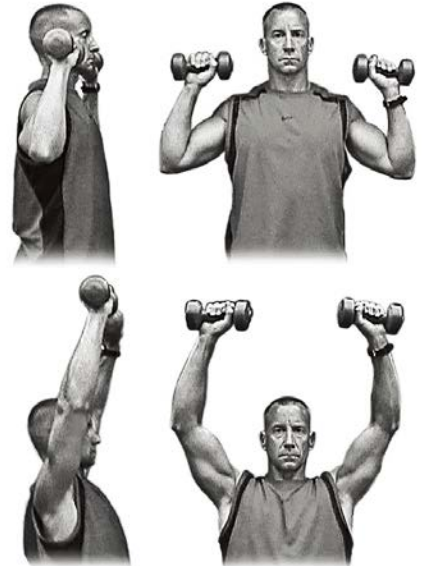

## DUMBBELL TRICEP OVERHEAD EXTENSION

EMPHASIS: BACK OF ARMS

1. Hold the dumbbells at shoulder height behind your head with a neutral grip (palms facing one another); your elbows should be pointed straight ahead
2. Raise the dumbbells overhead until your arms are fully extended; your upper arms should remain stationary, pivoting at the elbows
3. Slowly lower to the start position
4. Repeat this sequence for the duration of the strength interval



## DUMBBELL BICEP CURL

EMPHASIS: FRONT OF ARMS

1. Hold the dumbbells with an underhand grip (palms facing forward) beside your thighs
2. Tuck your upper arms into your ribcage
3. Curl the dumbbells to shoulder height by pivoting at your elbows
4. Slowly lower to the start position
5. Repeat this sequence for the duration of the strength interval

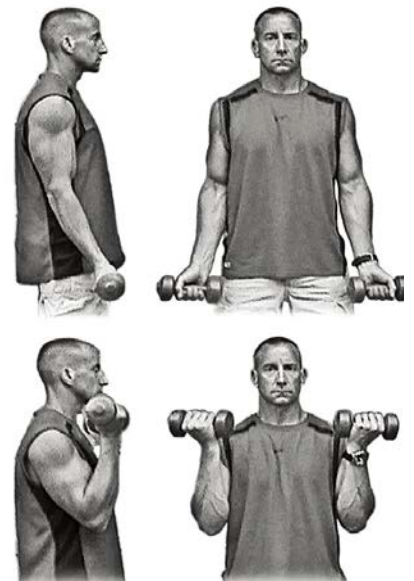



# PRESET PROGRAMS

The treadmill has seven different programs that have been designed for a variety of workouts. Five of these programs have factory preset Speed and Incline level profiles for achieving different goals.

## HILL

**Resistance:** This program follows a triangle or pyramid type of gradual progression from approximately 10% of maximum effort (the level that you chose before starting this program) up to a maximum effort which lasts for 10% of the total workout time, then a gradual regression of resistance back to approximately 10% of maximum effort.  
**Incline:** The deck elevation is a more gradual and sustained progression. Maximum elevation is in the middle of the workout and lasts for 10% of the duration.

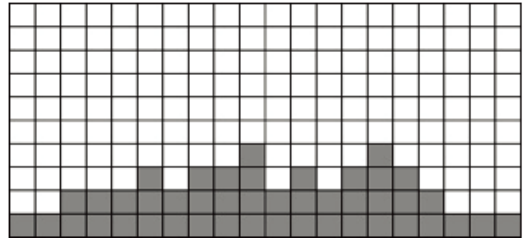
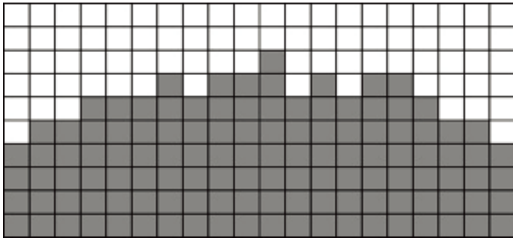

## FAT BURN

**Resistance:** This program follows a quick progression up to the maximum speed level (default or user input level) that is sustained for 2/3 of the workout. This program will challenge your ability to sustain your energy output for an extended period of time.  
**Incline:** The deck elevation is a quick and sustained progression up to the maximum value (default or user input) for 90% of the workout duration.

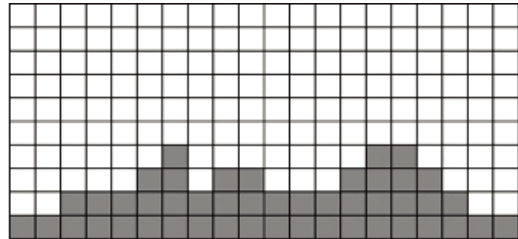
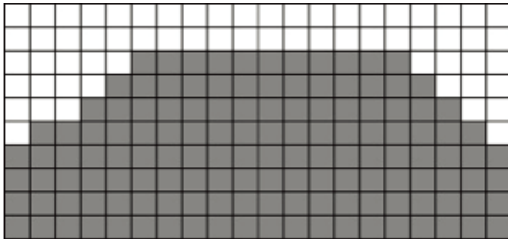

## CARDIO

**Resistance:** This program presents a quick progression up to near maximum speed level (default or user input level). It has slight fluctuations up and down to allow your heart rate to elevate and then recover repeatedly before beginning a quick cool down. This will build up your heart muscle and increase blood flow and lung capacity.  
**Incline:** The elevation in this program is moderate. There are several elevation spikes at different points of the workout. Segment 15 is maximum elevation for this program.

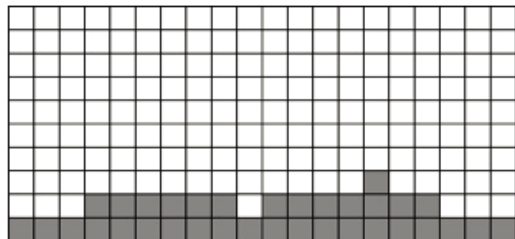
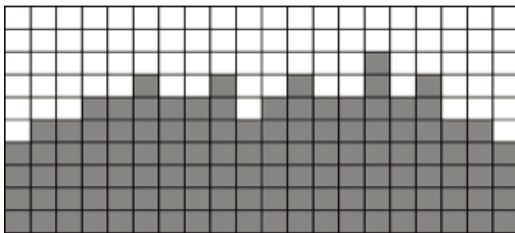

## STRENGTH

**Resistance:** This program has a gradual progression of speed up to 100% of maximum effort that is sustained for 25% of workout duration. This will help build strength and muscular endurance in the lower body and gluts. A brief cool down follows.

**Incline:** There is a quick climb to a moderate, sustained elevation that lasts the majority of the workout length.

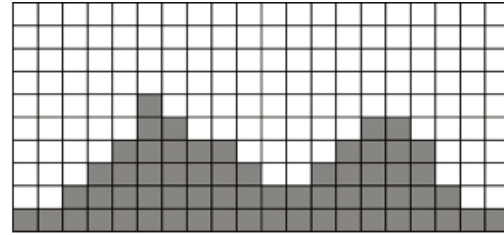
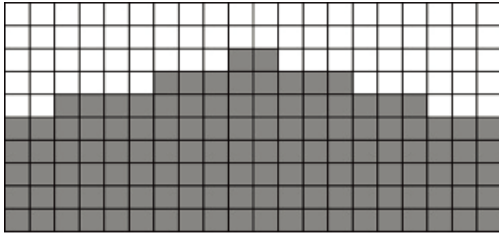

## INTERVAL

**Resistance:** This program takes you through high levels of intensity followed by recovery periods of low intensity. This program utilizes and develops your “Fast Twitch” muscle fibers which are used when performing tasks that are intense and short in duration. These deplete your oxygen level and spike your heart rate, followed by periods of recovery and heart rate drop to replenish oxygen. Your cardiovascular system gets programmed to use oxygen more efficiently.

**Incline:** This program will spike similar to the speed profile but in different segments (columns); this means that all of your lower extremity muscles will be equally challenged throughout this program. The incline alternates between 25 & 65 % of maximum elevation.

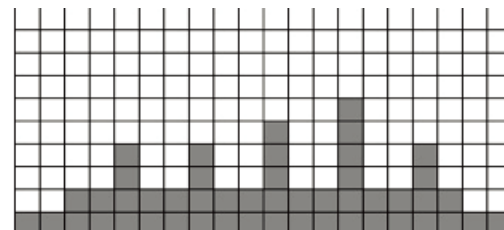
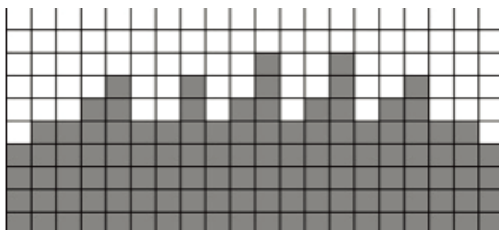

## CALORIES

**Resistance:** This program follows a quick progression up to the maximum speed level (default or user input level) that is sustained for 2/3 of the workout. This program will challenge your ability to sustain your energy output for an extended period of time.

**Incline:** The treadmill elevation is a quick and sustained progression up to the maximum value (default or user input) for 90% of the workout duration.

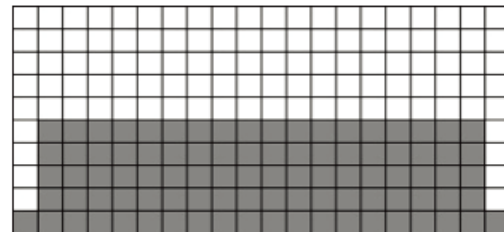
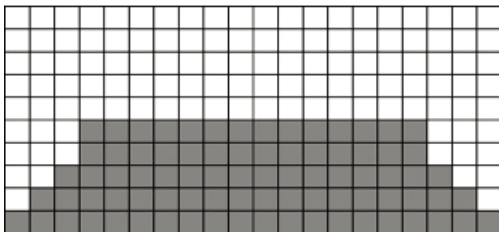

## FUSION

(Speed/Incline profile graphs are similar to the Interval Program)

**Resistance:** This program takes you through high levels of cardio & strength intensity followed by recovery periods of low intensity. This program utilizes and develops your “Fast Twitch” muscle fibers which are used when performing tasks that are intense and short in duration. These deplete your oxygen level and spike your heart rate, followed by periods of recovery and heart rate drop to replenish oxygen. Your cardiovascular system gets programmed to use oxygen more efficiently.

**Incline:** This program will spike similar to the speed profile but in different segments (columns); this means that all of your lower extremity muscles will be equally challenged throughout this program. The incline alternates between 25 & 65 % of maximum elevation.

# HEART RATE PROGRAMS

The old motto, “no pain, no gain,” is a myth that has been overpowered by the benefits of exercising comfortably. A great deal of this success has been promoted by the use of heart rate monitors. With the proper use of a heart rate monitor, many people find that their usual choice of exercise intensity was either too high or too low, and exercise is much more enjoyable by maintaining their heart rate in the desired benefit range.

To determine the benefits range in which you wish to train, you must first determine your Maximum Heart Rate. This can be accomplished by using the following formula: 220 minus your age. This will give you the Maximum Heart Rate (MHR) for someone of your age. To determine the effective heart rate range for specific goals, you simply calculate a percentage of your MHR. Your Heart rate training zone is 50% to 90% of your maximum heart rate. 60% of your MHR is the zone that burns fat, while 80% is for strengthening the cardiovascular system. This 60% to 80% is the zone to stay in for maximum benefit.

For someone who is 40 years old their target heart rate zone is calculated:

$220 - 40 = 180$  (maximum heart rate)  
 $180 \times .6 = 108$  beats per minute  
 (60% of maximum)  
 $180 \times .8 = 144$  beats per minute  
 (80% of maximum)

So for a 40-year-old, the training zone would be 108 to 144 beats per minute.

If you enter your age during programming, the console will perform this calculation automatically. Entering your age is used for the Heart Rate programs. After calculating your MHR, you can decide upon which goal you would like to pursue.

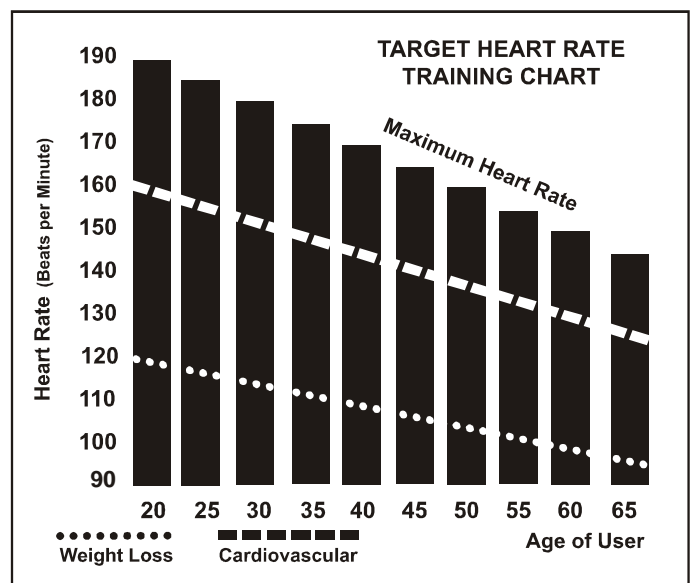

The two most popular reasons for, or goals, of exercise, are cardiovascular fitness (training for the heart and lungs) and weight control. The black columns on the chart above represent the MHR for a person whose age is listed at the bottom of each column. The training heart rate, for either cardiovascular fitness or weight loss, is represented by two different lines that cut diagonally through the chart. A definition of the lines' goal is in the bottom left-hand corner of the chart. If your goal is cardiovascular fitness or if it is weight loss, it can be achieved by training at 80% or 60%, respectively, of your MHR on a schedule approved by your physician. Consult your physician before participating in any exercise program.

# RATE OF PERCEIVED EXERTION

Heart rate is important but listening to your body also has a lot of advantages. There are more variables involved in how hard you should workout than just heart rate. Your stress level, physical health, emotional health, temperature, humidity, the time of day, the last time you ate and what you ate all contribute to the intensity at which you should workout. If you listen to your body, it will tell you all of these things.

The rate of perceived exertion (RPE), also known as the Borg scale, was developed by Swedish physiologist G.A.V. Borg. This scale rates exercise intensity from 6 to 20 depending upon how you feel or the perception of your effort.

The scale is as follows:

## Rating Perception of Effort

- 6** Minimal
- 7** Very, very light
- 8** Very, very light +
- 9** Very light
- 10** Very light +
- 11** Fairly light
- 12** Comfortable
- 13** Somewhat hard
- 14** Somewhat hard +
- 15** Hard
- 16** Hard +
- 17** Very hard
- 18** Very hard +
- 19** Very, very hard
- 20** Maximal

You can get an approximate heart rate level for each rating by simply adding a zero to each rating. For example, a rating of 12 will result in an approximate heart rate of 120 beats per minute. Your RPE will vary depending on the factors discussed earlier. That is the major benefit of this type of training. If your body is strong and rested, you will feel strong, and your pace will feel easier. When your body is in this condition, you are able to train harder, and the RPE will support this. If you are feeling tired and sluggish, it is because your body needs a break. In this condition, your pace will feel harder. Again, this will show up in your RPE, and you will train at the proper level for that day.

# USING HEART RATE TRANSMITTER

How to wear your wireless chest strap transmitter:

1. Attach the transmitter to the elastic strap using the locking parts.
2. Adjust the strap as tightly as possible as long as the strap is not too tight to remain comfortable.
3. Position the transmitter with the logo centred in the middle of your torso facing away from your chest (some people must position the transmitter slightly left of center). Attach the final end of the elastic strap by inserting the round end and using the locking parts, secure the transmitter and strap around your chest.
4. Position the transmitter directly below the pectoral muscles.
5. Sweat is the best conductor to measure very minute heartbeat electrical signals. However, plain water can also be used to pre-wet the electrodes (2 ribbed oval areas on the reverse side of the belt and both sides of the transmitter). It's also recommended that you wear the transmitter strap a few minutes before your workout. Some users, because of body chemistry, have a more difficult time in achieving a strong, steady signal at the beginning. After "warming up," this problem lessens. As noted, wearing clothing over the transmitter/strap doesn't affect performance.
6. Your workout must be within range - the distance between transmitter/receiver - to achieve a strong, steady signal. The length of the range may vary somewhat but generally stay close enough to the console to maintain good, strong, reliable readings. Wearing the transmitter directly on bare skin assures you of proper operation. If you wish, you may wear the transmitter over a shirt. To do so, wet the areas of the shirt that the electrodes will rest upon.



**Note:** The transmitter is automatically activated when it detects activity from the user's heart. Additionally, it automatically deactivates when it does not receive any activity. Although the transmitter is water resistant, moisture can have the effect of creating false signals, so you should take precautions to completely dry the transmitter after use to prolong battery life (estimated transmitter battery life is 2500 hours). The replacement battery is Panasonic CR2032.

## ERRATIC OPERATION

Caution! Do not use this treadmill for Heart Rate programs unless a steady, solid Actual Heart Rate value is being displayed. High, wild, random numbers being displayed indicate a problem.

Areas to look for interference that may cause erratic heart rate:

1. Treadmill not properly grounded - Proper grounding is a must!
2. Microwave ovens, TVs, small appliances, etc.
3. Fluorescent lights.
4. Some household security systems.
5. Perimeter fence for a pet.
6. Some people have problems with the transmitter picking up a signal from their skin. If you have problems, try wearing the transmitter upside down. Normally the transmitter will be oriented, so the logo is right side up.
7. The antenna that picks up your heart rate is very sensitive. If there is an outside noise source, turning the whole machine 90 degrees may de-tune the interference.
8. Another Individual wearing a transmitter within 3' of your machine's console.

If you continue to experience problems, contact your dealer.

**WARNING! - DO NOT USE THE HEART RATE PROGRAM IF YOUR HEART RATE IS NOT REGISTERING PROPERLY ON THE TREADMILL'S DISPLAY!**

# HEART RATE PROGRAM OPERATION

**Note:** You must wear the heart rate transmitter strap for these programs

Both programs operate the same; the only difference is that **HR1** is set to 60%, and **HR2** is set to 80% of the maximum heart rate. They both are programmed the same way. To start an HR program, follow the instructions below or just select the **HR1** or **HR2** program, then the Enter button and follow the directions in the **Message Center**.

After selecting your heart rate target, the program will attempt to keep you at or within 3 - 5 heartbeats per minute of this value. Follow the prompts in the **Message Center** to maintain your selected heart rate value.

1. Press the **HR 1-2 key** once (60% of max heart rate default) or twice (80% of max heart rate default) key, then press the **Enter** key.
2. The Message Center will ask you to enter your Age. You may enter your age using the **Speed + or – keys**, then press the **Enter** key to accept the new value and proceed on to the next screen.
3. You are now asked to enter your **Weight**. You may adjust the weight value using the **Speed + or – keys**; then press **Enter** to continue.
4. Next is **Time**. You may adjust the time using the **Speed + or – keys** and press **Enter** to continue.
5. Now, you are asked to adjust the Heart Rate Target. This is the heart rate level you will strive to maintain during the program. Adjust the level using the **Speed + or – keys**, then press **Enter**.  
**Note:** The heart rate that appears is based on the % you accepted in Step 1. If you change this number, it will either increase or decrease the % from Step 1.
6. Now you are finished editing the settings and can begin your workout by pressing the **Start** key. You can also go back and modify your settings by pressing the **Stop** key.  
**Note:** At any time during the editing of Data, you can press the Stop key to go back to one screen.
7. If you want to increase or decrease the workload at any time during the program, press the **Incline + or – key** on the console or left handlebar. This will allow you to change your target heart rate at any time during the program.
8. During the **HR 1** or **HR 2** programs, you will be able to scroll through the data in the **Message Center** by pressing the **Enter** key.
9. When the program ends, you may press **Start** to begin the same program again or press **Stop** to exit the program.



# PARTS LIST

KEY #	PART #	Part description	Q'ty
1	6068501	Main Frame	1
2	6068502	Incline Bracket	1
3	6068503	Handrail Support	1
4	6068504	Right Upright	1
5	6068505	Left Upright	1
6	6068506	Console Support	1
7	6068507	Gusset (L)	1
8	6068508	Gusset (R)	1
9	6068509	Drive Belt	1
10	6068510	Front Roller W/Pulley	1
10~3	6068510-3	Magnet	2
11	6068511	Rear Roller	1
12	6068512	Running Deck	1
13	6068513	Running Belt	1
14	6068514	PVC Handgrip	2
15	6068515	Deck Cross Brace	1
17	6068517	Wire Tie Mount	6
19	6068519	Frame Cover	1
20	6068520	Drive Motor	1
21	6068521	Incline Motor	1
22~1	6068522-1	Motor Controller	1
23	6068523	1200m/m_Sensor W/Cable	1
24	6068524	Breaker	1
25	6068525	Power Socket	1
26	6068526	On/Off Switch	1
27	6068527	Power Cord	1
28	6068528	100m/m_Connecting Wire (Black)	1
29	6068529	350m/m_Connecting Wire (White)	1
30	6068530	350m/m_Connecting Wire (Black)	1
31	6068531	800m/m_Computer Cable (Upper)	1
32	6068532	1250m/m_Computer Cable(Middle)	1
33	6068533	550m/m_Computer Cable (Lower)	1
34	6068534	800m/m_Speed Cable (Upper)	1
35	6068535	800m/m_Incline Cable (Upper)	1
36	6068536	Console Assembly	1
37	6068537	300m/m_Speed Adjustment Switch W/Cable	1
38	6068538	300m/m_Incline Adjustment Switch W/Cable	1
39~1	6068539-1	Handpulse Plate	4
39~2	6068539-2	1100m/m_Handpulse Wire(White)	1
39~3	6068539-3	1100m/m_Handpulse Wire(Red)	1
39~4	6068539-4	Handpulse Top Cover	2
39~5	6068539-5	Handpulse Bottom Cover	2
41	6068541	Cushion	6



KEY #	PART #	Part description	Q'ty
42	6068542	Ø82 x Ø14 x 35L_Transportation Whee	4
43	6068543	Motor Top Cover	1
44	6068544	Aluminum Foot Rail	2
45	6068545	Foot Rail Cap (L)	1
46	6068546	Foot Rail Cap (R)	1
47	6068547	Handgrip End Cap	2
48	6068548	Handpulse End Cap Top Cover	2
49	6068549	Handpulse End Cap Bottom Cover	2
50	6068550	Front Motor Cover	1
51	6068551	Motor Cover Anchor(D)	2
52	6068552	Upright Cover(L)	1
53	6068553	Upright Cover(R)	1
54	6068554	Fan Mounting Plate	1
56	6068556	Rear Adjustment Base (L)	1
57	6068557	Rear Adjustment Base (R)	1
58	6068558	Ø24 x Ø10 x 3T_Nylon Washer (A)	2
59	6068559	Ø50 x Ø13 x 3T_Nylon Washer (B)	4
60	6068560	Adjustment Foot Pad	2
62	6068562	Quadrate Safety Key	1
64	6068564	1/2" x 57L_Hex Head Bolt	2
65	6068565	3/8" x 4-1/2" _Socket Head Cap Bolt (Alloy Steel)	1
66	6068566	3/8" x 4" _Socket Head Cap Bolt (Alloy Steel)	1
67	6068567	3/8" x 1-3/4" _Hex Head Bolt	1
68	6068568	M8 x 60m/m_Hex Head Bolt	1
69	6068569	M8 x 80m/m_Socket Head Cap Bolt	2
70	6068570	M8 x 55m/m_Flat Head Countersink Bolt	2
71	6068571	M8 x 35m/m _Flat Head Countersink Bolt	6
72	6068572	3/8" x 3/4" _Button Head Socket Bolt	4
73	6068573	3/8" x 1-1/4" _Hex Head Bolt	4
74	6068574	M5 x 10m/m_Phillips Head Screw	4
75	6068575	Ø5 x 1.5T_Spring Washer	4
76	6068576	1/2" x 15T_Nyloc Nut	2
77	6068577	3/8" x 7T_Nyloc Nut	2
78	6068578	M8 x 7T_Nyloc Nut	1
79	6068579	Ø3/8" x Ø19 x 1.5T_Flat Washer	12
80	6068580	Ø3/8" x Ø25 x 2.0T_Flat Washer	4
81	6068581	Ø6.5 x Ø16 x 1.0T_Flat Washer	5
83	6068583	M5_Star Washer	8
84	6068584	Ø6 x Ø23 x Ø13 x 5.5T x 3T_Nylon Dished Washer	4
85	6068585-1	Ø5.5 x 27 x 60 x 1.5T x 3.5H_ Concave Washer	4
86	6068586	Ø10 x 2.0T_Spring Washer	14
87	6068587	5 x 19m/m_Tapping Screw	2
88	6068588	Ø5 x 16L_Tapping Screw	35
89	6068589	4 x 12m/m_Sheet Metal Screw	1
90	6068590	3.5 x 12m/m_Sheet Metal Screw	35
91	6068591	3/8" x 1-3/4" _Button Head Socket Bolt	4

<b>KEY #</b>	<b>PART #</b>	<b>Part description</b>	<b>Q'ty</b>
93	6068593	5 x 16m/m_Tapping Screw	9
94	6068594	3 x 10m/m_Tapping Screw	6
95	6068595	4 x 50m/m_Sheet Metal Screw	2
96	6068596	3 x 10m/m_Sheet Metal Screw	2
97	6068597	3.5 x 16m/m_Tapping Screw	6
98	6068598	Console Mast Side Cap (L)	1
99	6068599	Console Mast Side Cap (R)	1
100	60685100	5/16" x 3/4"_Button Head Socket Bolt	8
101	60685101	Fixing Plate Stabilizer	2
102	60685102	3/8" x 2-1/4"_Flat Head Socket Bolt	4
103	60685103	Combination M5 Allen Wrench & Phillips Head Screwdriver	1
104	60685104	L Allen Wrench	1
106	60685106	3/8" x 7T_Luck Nut	3
107	60685107	3 x 8m/m_Sheet Metal Screw	8
109	60685109	Square End Cap	4
110	60685110	Controller Back Plate	1
112	60685112	Fan	1
113	60685113	400m/m_Motor Fan Connecting Cable	1
114	60685114	400m/m_Motor Fan Connecting Cable	1
115	60685115	Chest Strap	1
116	60685116	400m/m_Audio Cable	1
117	60685117	600m/m_Ground Wire	1
120	60685120	Beverage Holder	1
123	60685123	3/8" x 2-1/2"_Button Head Socket Bolt	6
124	60685124	Curved Washer	4
125	60685125	Ø3.5 x 16L_Sheet Metal Screw	8
126	60685126	Phillips Head Screwdriver	1
127	60685127	M5 x 10m/m_Phillips Head Screw	4
128	60685128	Nyloc Nut	2
129	60685129	3.5 x 55m/m_Sheet Metal Screw	1
130	60685130	Safety Key Sleeve	1
131	60685131	M4 x 35m/m_Phillips Head Screw	2
168	60685168	Ø8.5 x Ø16 x 1.5T_Flat Washer	2

# GENERAL MAINTENANCE

## BELT & DECK

Your treadmill uses a very high-efficient low-friction hard waxed deck. Performance is maximized when the deck is kept as clean as possible. Use a soft, damp cloth, or paper towel, wipe the edge of the belt and the area between the belt edge and the frame. Also, reach as far as practical directly under the belt edge. This should be done once a month to extend belt and deck life. A mild soap and water solution along with a nylon scrub brush will clean the top of the textured belt. Allow drying before using.

If the original side of the deck shows significant wear, it needs to be flipped. Contact your service technician for assistance.

**Do not apply any type of lubricant or wax to the surface.**

## BELT DUST

This occurs during normal break-in or until the belt stabilizes. Wiping excess off with a damp cloth will minimize buildup.

## GENERAL CLEANING

Dirt, dust, and pet hair can block air inlets and accumulate on the running belt. On a monthly basis, vacuum underneath your treadmill to prevent buildup. Once a year, you should remove the black motor hood and vacuum out dirt that may accumulate. **UNPLUG POWER CORD BEFORE THIS TASK.**

## BELT ADJUSTMENTS

Tread-belt Tension Adjustment - Belt tension is not critical for most users. It is very important for joggers and runners in order to provide a smooth, steady running surface. Adjustment must be made from the right side of the rear roller in order to adjust tension with the 6 mm Allen wrench provided in the parts package. The adjustment bolt is located at the end of the right side rail, as noted in diagram below.

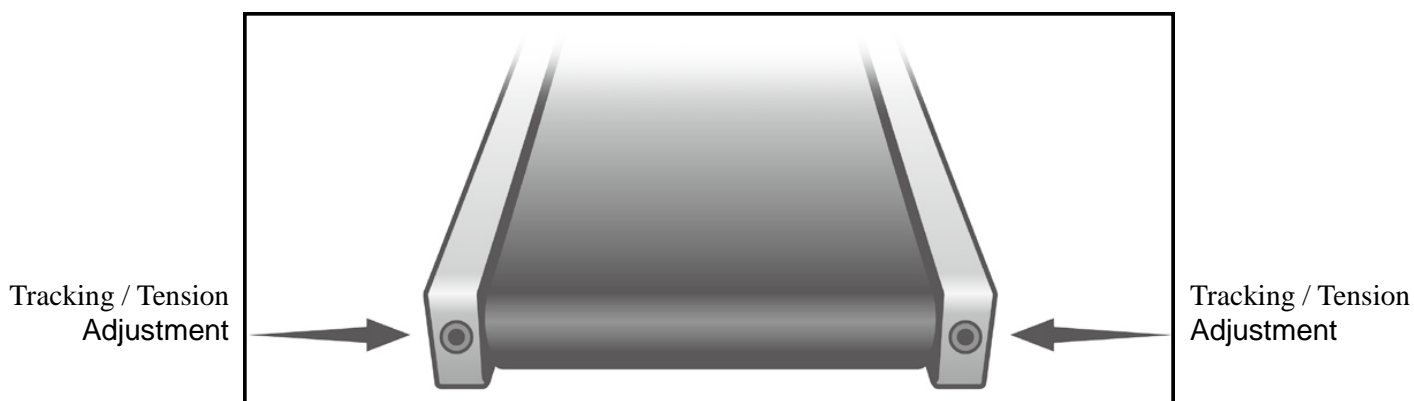

**Note:** Adjustment is through small hole in end

Tighten the rear roller only enough to prevent slippage at the front roller. Turn the tread-belt tension adjusting bolt in increments of 1/4 turn and inspect for proper tension.

When an adjustment is made to the belt tension, you must also make a tracking adjustment to compensate for the change in belt tension. This is accomplished by turning both the tension and tracking Allen bolts an equal amount. This adjustment should be made by turning both bolts clockwise by no more than a 1/4 turn at a time.

**DO NOT OVERTIGHTEN** – Over tightening will cause belt damage and premature bearing failure.

# TREADBELT TRACKING ADJUSTMENT

The performance of your treadmill is dependent on the frame running on a reasonably level surface. If the frame is not level, the front and back roller cannot run parallel, and constant belt adjustment may be necessary. The treadmill is designed to keep the tread-belt reasonably centred while in use. It is normal for some belts to drift near one side while the belt is running with no one on it. After a few minutes of use, the tread-belt should have a tendency to center itself. If during use, the belt continues to move toward one side, adjustments are necessary.

## TO SET TREADBELT TRACKING

A 6 mm Allen wrench is provided to adjust the rear roller. Make tracking adjustments from the **left** side only. Set belt speed at approximately 2 to 3 MPH. A small adjustment can make a dramatic difference. Turn the bolt only a 1/4 turn and wait a few minutes for the belt to adjust itself. Continue to make 1/4 turns until the belt stabilizes in the center of the running deck. The belt may require periodic tracking adjustment depending on use and walking/running characteristics. Some users will affect tracking differently. Expect to make adjustments as required to center the tread-belt. Adjustments will become less of a maintenance concern as the belt is used. Proper belt tracking is an owner responsibility common with all treadmills.

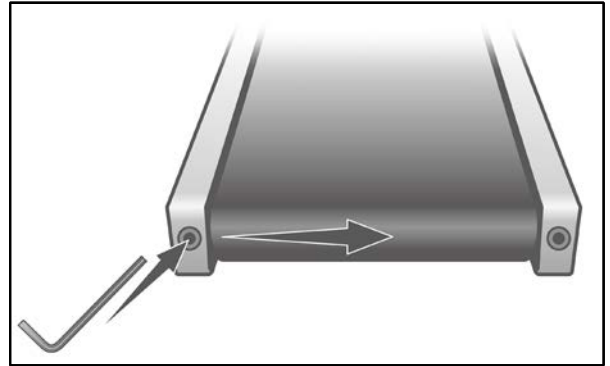

### ATTENTION:

**DAMAGE TO THE RUNNING BELT RESULTING FROM IMPROPER TRACKING / TENSION ADJUSTMENTS ARE NOT COVERED UNDER THE SPIRIT WARRANTY.**

# SERVICE CHECKLIST - DIAGNOSIS GUIDE

Before contacting your dealer for aid, please review the following information. It may save you both time and expense. This list includes common problems that may not be covered under the treadmill's warranty.

PROBLEM	SOLUTION/CAUSE
<b>Display does not light</b>	<ol style="list-style-type: none"> <li>1. Tether cord not in position.</li> <li>2. Circuit breaker on front grill tripped. Push circuit breaker in until it locks.</li> <li>3. Plug is disconnected. Make sure plug is firmly pushed into AC household wall outlet.</li> <li>4. Household circuit breaker may be tripped.</li> <li>5. Treadmill defect. Contact your dealer.</li> </ol>
<b>Tread-belt does not stay centered Treadmill belt hesitates when walked/run on</b>	<p>The user may be walking while favouring or putting more weight on either the left or right foot. If this walking pattern is natural, track the belt slightly off-center to the side opposite from the belt movement. See <b>General Maintenance</b> section on <b>Tread-belt Tension</b>. Adjust as necessary.</p>
<b>Motor is not responsive after pressing start</b>	<ol style="list-style-type: none"> <li>1. If the belt moves but stops after a short time and the display shows "E1", run calibration.</li> <li>2. If you press start and the belt never moves, then the display shows E1, contact service.</li> </ol>
<b>Treadmill will only achieve approximately 12 KPH (7 MPH) but shows higher speed on display</b>	<p>This indicates motor should be receiving power to operate. Low AC voltage to treadmill. Do not use an extension cord. If an extension cord is required, it should be as short as possible and heavy duty 16 gauge minimum. Low household voltage. Contact an electrician or your dealer. A minimum of 110 volt AC current is required.</p>
<b>Tread-belt stops quickly/suddenly when tether cord is pulled</b>	<p>High belt/deck friction. See General Maintenance section on cleaning the deck. If cleaning doesn't prevent this from reoccurring, check to see if there is significant wear on the deck. If so, the deck may need to be flipped if it is on its original side.</p>
<b>Treadmill trips on board 15 amp circuit</b>	<p>High belt/deck friction. See <b>General Maintenance</b></p>
<b>Computer shuts off when console is touched (on a cold day) while walking/running</b>	<p>Treadmill may not be grounded. Static electricity is "crashing" the computer. Refer to <b>Grounding Instructions</b>.</p>
<b>House circuit breaker trips, but not the treadmill circuit breaker</b>	<p>Check that the treadmill is the only object in the circuit. See "Important Electrical Information" in the front of this manual for more details.</p>

## CALIBRATION PROCEDURE

1. Remove the safety key
2. Press and hold down the **Start** and **Speed +** buttons and replace the safety key. Continue to hold the **Start** and **Fast** key until the window displays “Factory settings,” then press the **Enter** key.
3. You will now be able to set the display to show Metric or English settings (Miles vs. Kilometers). To do this, press the **up or down** key to show which you want, then press **Enter**. (The maximum speed is displayed in the speed window, and the maximum elevation is displayed in the incline window.)
4. Grade return – On (This allows the incline to return to zero when Stop is pressed.)
5. Press **Start** to begin calibration. The process is automatic; the speed will start up without warning, so do not stand on the belt.

## ADJUSTING THE SPEED SENSOR

If the calibration does not pass, you may need to check the speed sensor alignment.

1. Remove the motor cover hood by loosening the 4 screws that hold it in place (you do not need to remove them completely).
2. The speed sensor is located on the left side of the frame, right next to the front roller pulley (the pulley will have a belt around it that also goes to the motor). The speed sensor is small and black with a wire connected to it.
3. Make sure the sensor is as close as possible to the pulley without touching it. You will see a magnet on the face of the pulley; make sure the sensor is aligned with the magnet. There is a screw that holds the sensor in place that needs to be loosened to adjust the sensor.  
Re-tighten the screw when finished.

## ENGINEERING MODE MENU

The console has built in maintenance/diagnostic software. The software will allow you to change the console settings from English to Metric and turn off the beeping of the speaker when a key is pressed, for example. To enter the Engineering Mode Menu, press and hold down the **Start**, **Stop** and **Enter** keys. Keep holding the keys down for about 5 seconds, and the Message Center will display Engineering Mode Menu. Press the **Enter** key to access the menu below:

1. **Key Test** (Will allow you to test all the keys to make sure they are functioning)
2. **Display Test** (Tests all the display functions)
3. **Functions** (Press **Enter** to access settings and **Speed Up or Down** arrow to scroll)
  - I. **Display Mode** (Turn on to have the console power down automatically after 30 minutes of inactivity)
  - II. **Pause Mode** (Turn on allow 5 minutes of pause, turn off to have the console pause indefinitely)
  - III. **Maintenance** (Allows you to reset the lube message time)
  - IV. **Units** (Sets the display to readout in English or Metric display measurements)
  - V. **Beep** (Turns off the speaker, so no beeping sound is heard)
4. **Security** (Allows the keypad to be locked to prevent unauthorized use)
5. **Exit**

## MANUFACTURER LIMITED WARRANTY, REPAIR AND SERVICE

WHAT DOES THIS WARRANTY COVER? This warranty covers your Spirit Treadmill against defects in material and workmanship when used for the purpose intended, under normal conditions and provided it receives proper care.

### HOW LONG DOES THE COVERAGE LAST?

Residential: Frame/Lifetime Motor & Deck/Lifetime Parts/10 years Labour/1 year

Light Commercial: Frame/Lifetime Motor/5 years Deck/3 years Parts/3 years Labour/1 year

(Non-dues paying facility) \* 6 months: Wear items (Rubber Hand Grips, Console Overlay and Drive Belts)

WHAT WILL DYACO CANADA INC DO? Dyaco Canada Inc. will provide a replacement part and/or service at no charge for any part found defective in workmanship or materials during the warranty period.

HOW DO YOU GET SERVICE? In order to obtain replacement parts or service as provided by this warranty, you may call the number below: 1-888-707-1880 Monday to Friday 8:30 a.m. to 5:00 p.m. eastern standard time.

The warranty registration can be completed online: Go to [www.dyaco.ca/warranty.html](http://www.dyaco.ca/warranty.html) and complete the online warranty registration.

This warranty shall not apply to treadmills which are (1) used for commercial or other income producing purpose, or (2) subject to misuse, neglect, accident or unauthorized repairs and alterations

This warranty provided herein is in lieu of all other express warranties. Any implied warranties, including any implied warranties of merchantability or fitness for particular purpose, are limited in duration to the first 24 months from the date of purchase. All other obligations or liabilities, including liability for consequential damages, are hereby excluded

All of the parts for the Spirit Treadmill, shown in figure, can be ordered from Dyaco Canada Inc., 5955 Don Murie Street, Niagara Falls, Ontario L2G 0A9. When ordering parts, the parts will be sent and billed at the current prices. Prices may be subject to change without notice. Cheque or money order must accompany all orders. Standard hardware items are available at your local hardware store.

To ensure prompt and correct handling of any errors, or to answer any questions, please call our Toll Free number, 1-888-707-1880, or local number 1-905-353-8955 or fax 1-905-353-8968 or email us at [customerservice@dyaco.ca](mailto:customerservice@dyaco.ca) Office hours are from 8:30 A.M. to 5:00 P.M. Monday to Friday Eastern Standard time.

Always include the following information when ordering parts:

\*Model number

\*Name of each part

\*Part number of each part

# dyaco

Please visit us online for information about our other brands and products manufactured and distributed by Dyaco Canada Inc.

**SPIRIT**

[spiritfitness.ca](http://spiritfitness.ca)

**XTEERRA**

[xterrafitness.ca](http://xterrafitness.ca)

**UFC**

[dyaco.ca/UFC/UFC-home.html](http://dyaco.ca/UFC/UFC-home.html)

**SOLE**  
FITNESS

[solefitness.ca](http://solefitness.ca)

**EVERLAST**

[dyaco.ca/products/everlast.html](http://dyaco.ca/products/everlast.html)

**Johnny G**  
by **SPIRIT**

[spiritfitness.ca/johnnyg.html](http://spiritfitness.ca/johnnyg.html)

**TRINOR**  
**SPORTS**

[trainorsports.ca](http://trainorsports.ca)

For more information, please contact Dyaco Canada Inc.  
T: 1-888-707-1880 | 5955 Don Murie St., Niagara Falls, Ontario L2G 0A9 | [sales@dyaco.ca](mailto:sales@dyaco.ca)

Dyaco Canada Inc. [dyaco.ca](http://dyaco.ca)